

Preparing Door

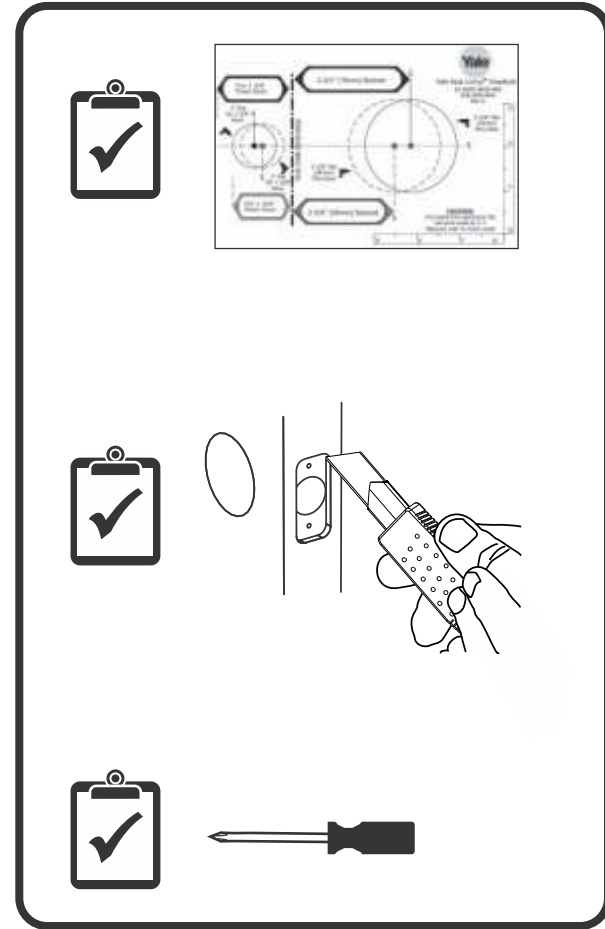

1 Installing Latch & Strike Plate

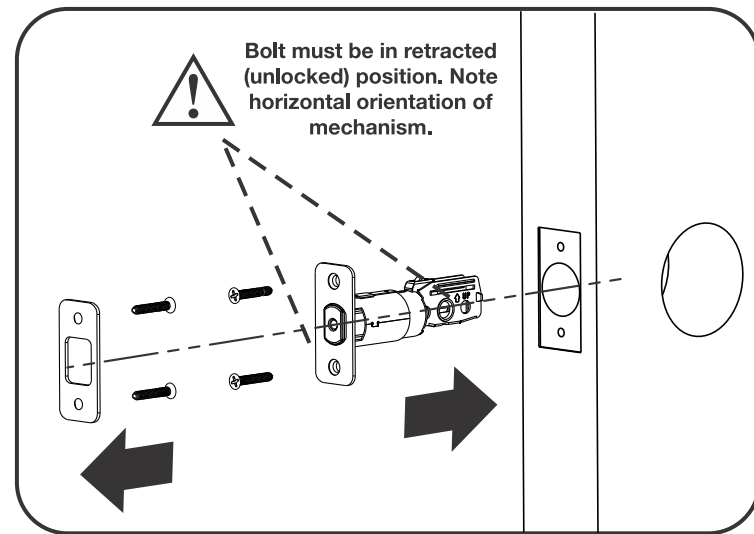
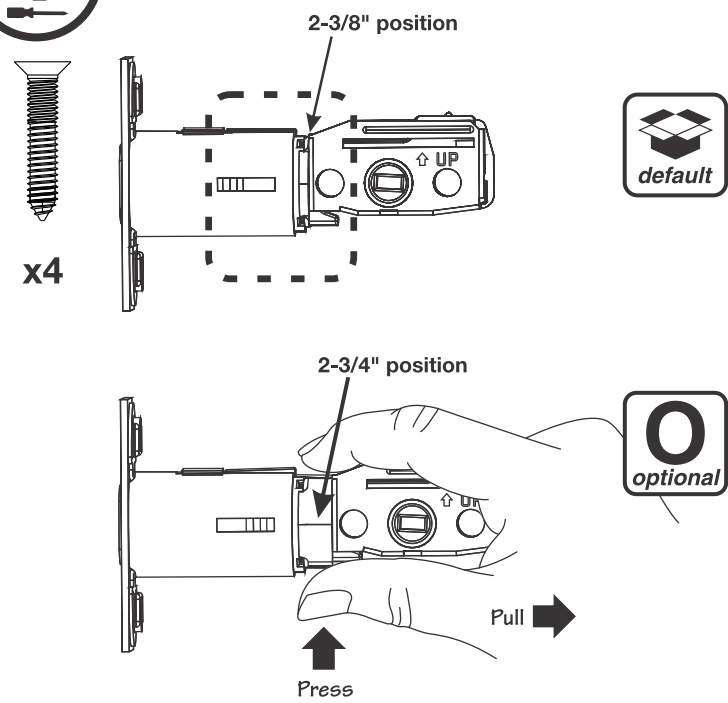

2 Installing Keypad Escutcheon

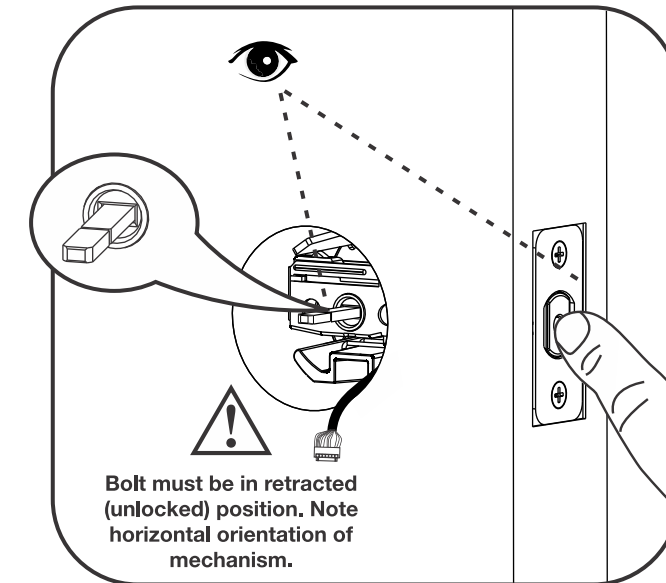
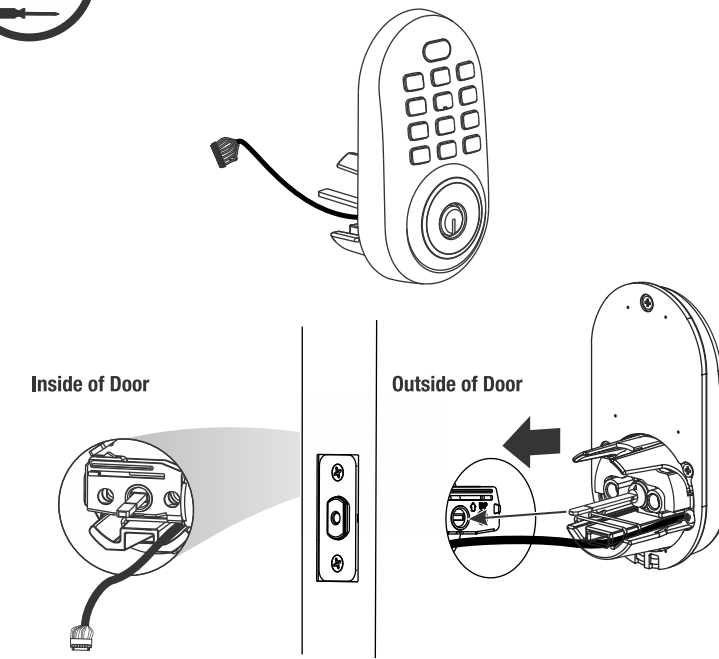

3 Installing Interior Mounting Plate

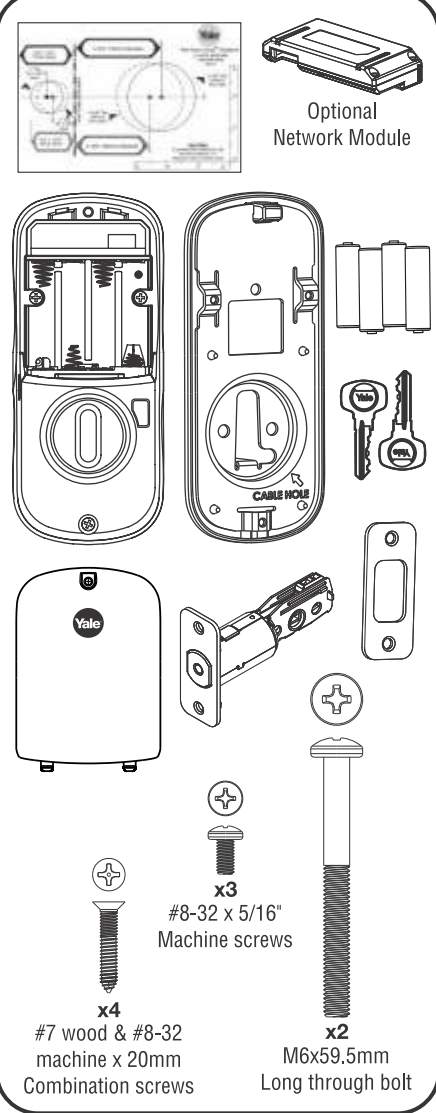
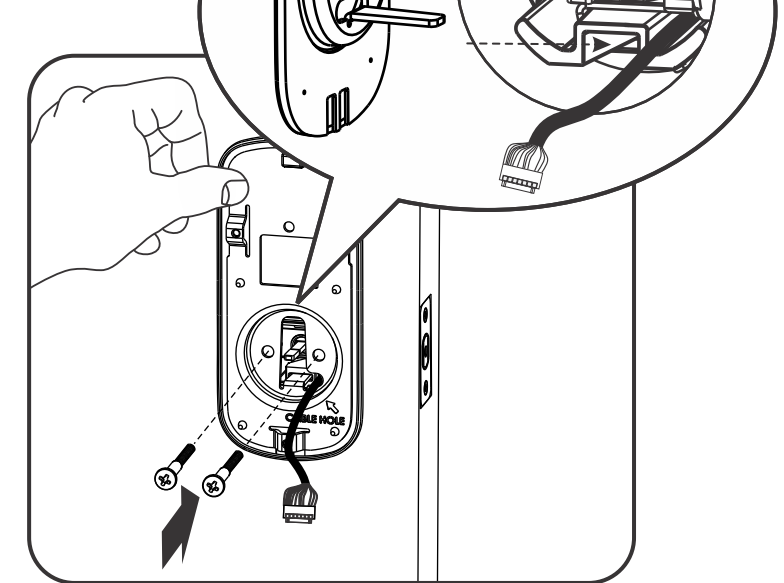
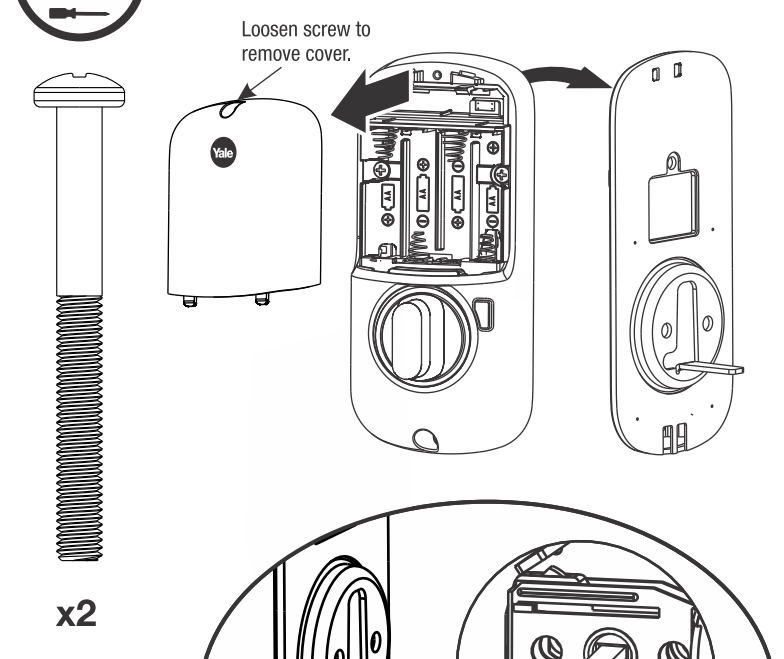

FAILURE TO FOLLOW THESE INSTRUCTIONS COULD RESULT IN DAMAGE TO THE PRODUCT AND VOID THE FACTORY WARRANTY

An ASSA ABLOY Group brand

P/N YRL-PBINSTL-FUL Rev D

ASSA ABLOY

4 Attaching the Cable Assembly

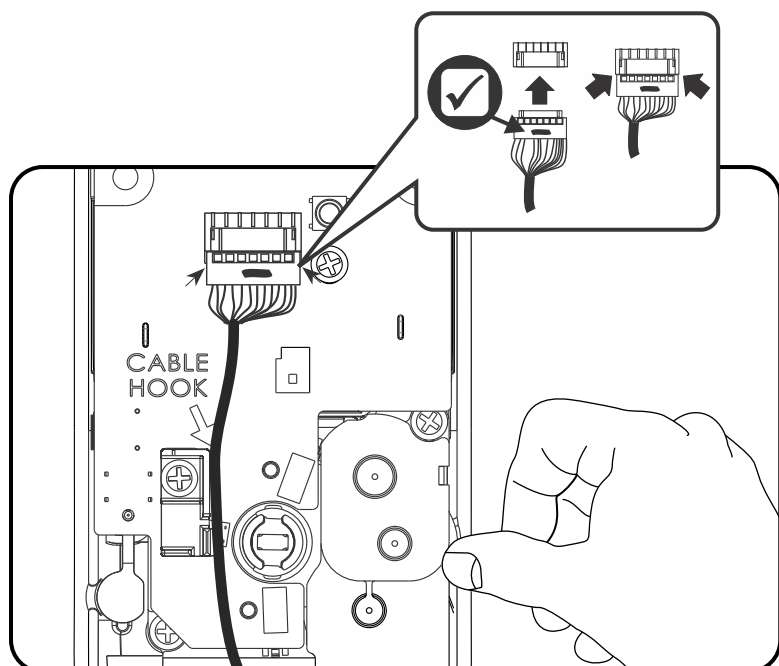
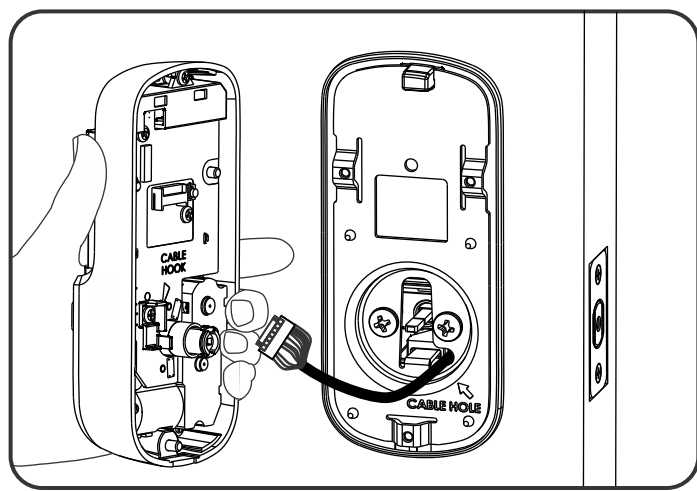

5 Installing Interior Escutcheon

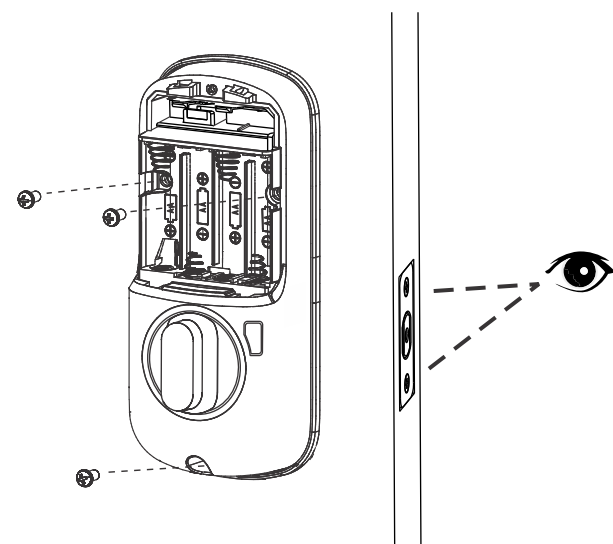
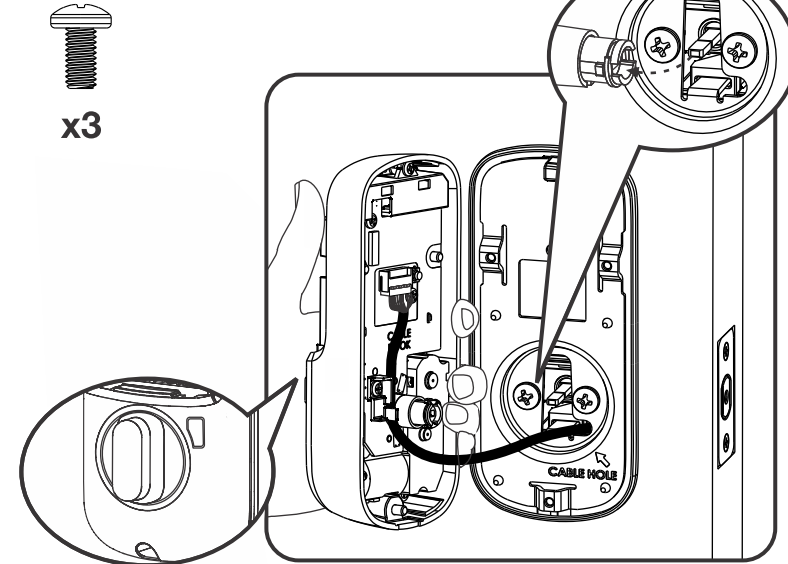

Testing Operation

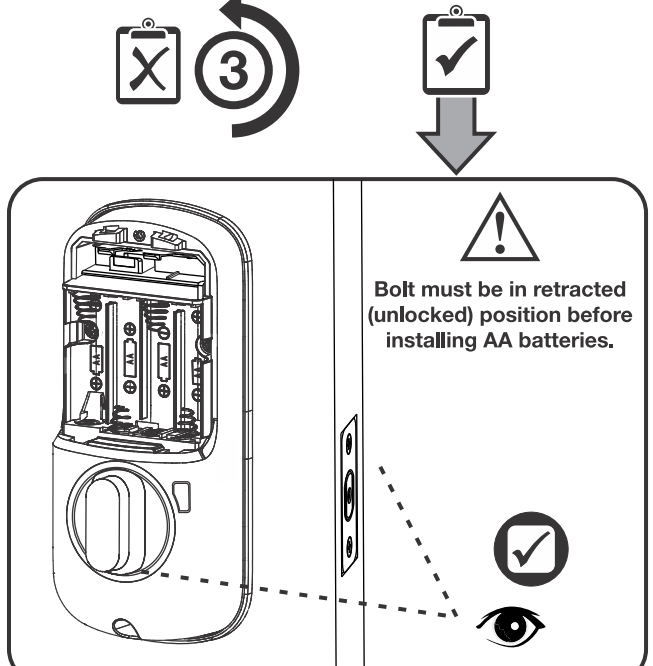
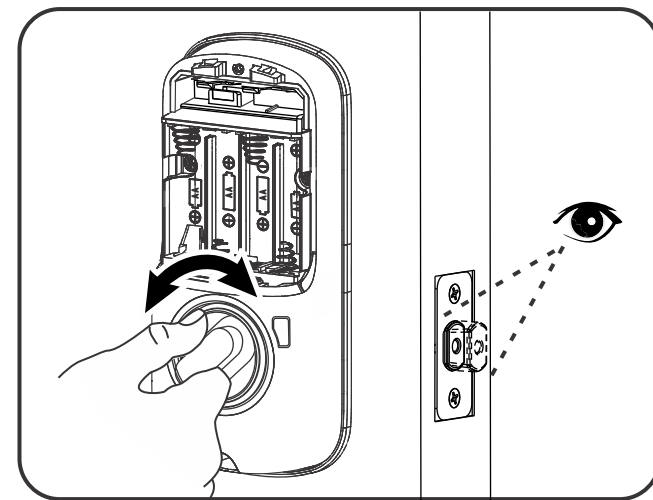

Testing Operation

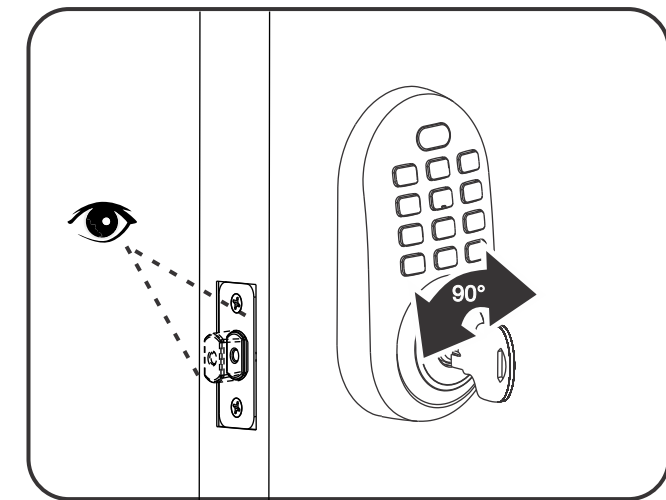

6 Installing Optional Network Module

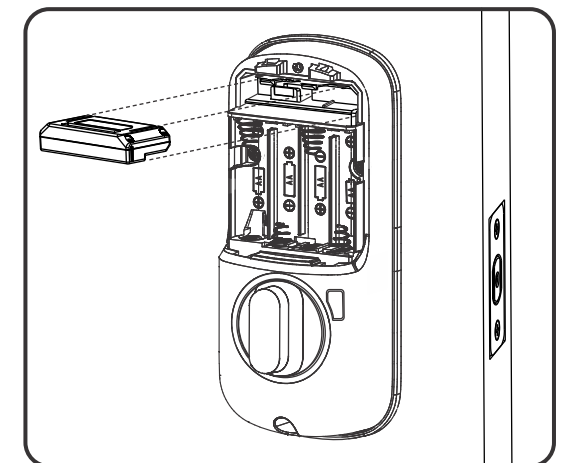

7 Installing Batteries & Cover

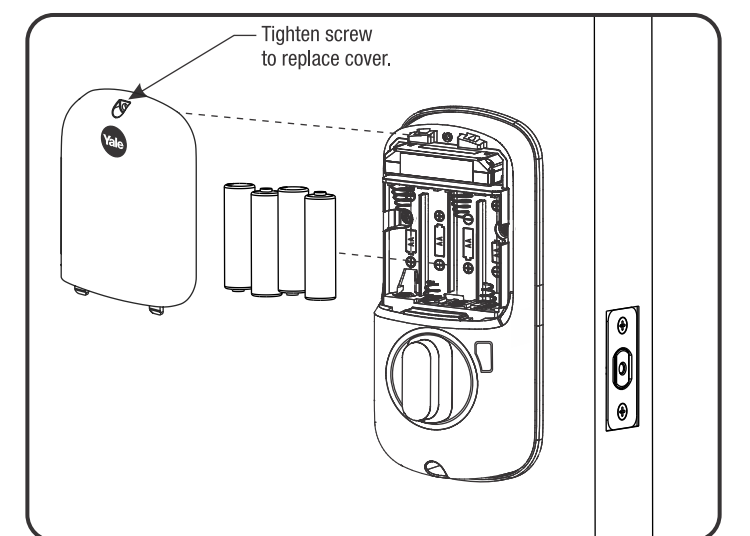

Congratulations, you've installed the Yale Real Living® Assure Lock® Push Button Deadbolt (YRD216)! Turn sheet over for Programming Instructions to customize your product.

Programming Instructions

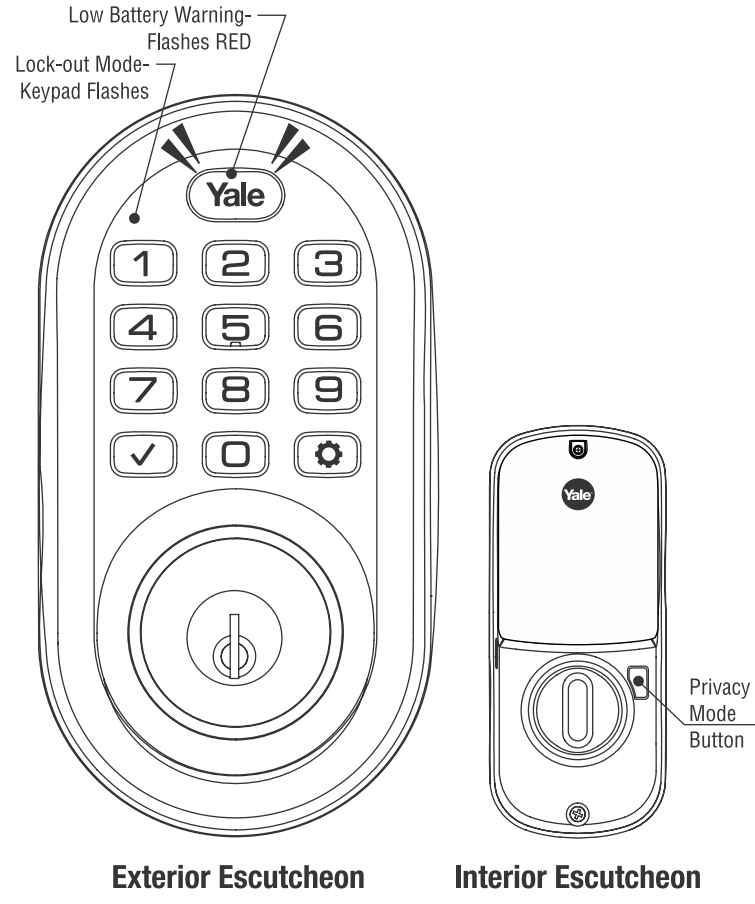

Master PIN Code must be created before any further programming.
Max User Codes = 250 with Network Module. Max User Codes = 25 without.

1 Creating Master PIN Code

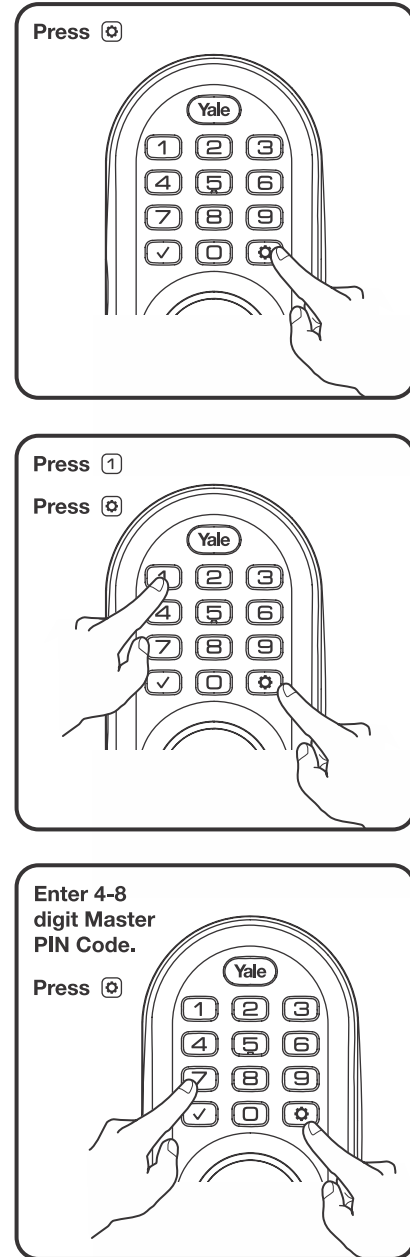

2 Creating User PIN Codes

Master PIN code must be created first.
*Max User Codes = 250 with Network Module. Max user codes = 25 without.

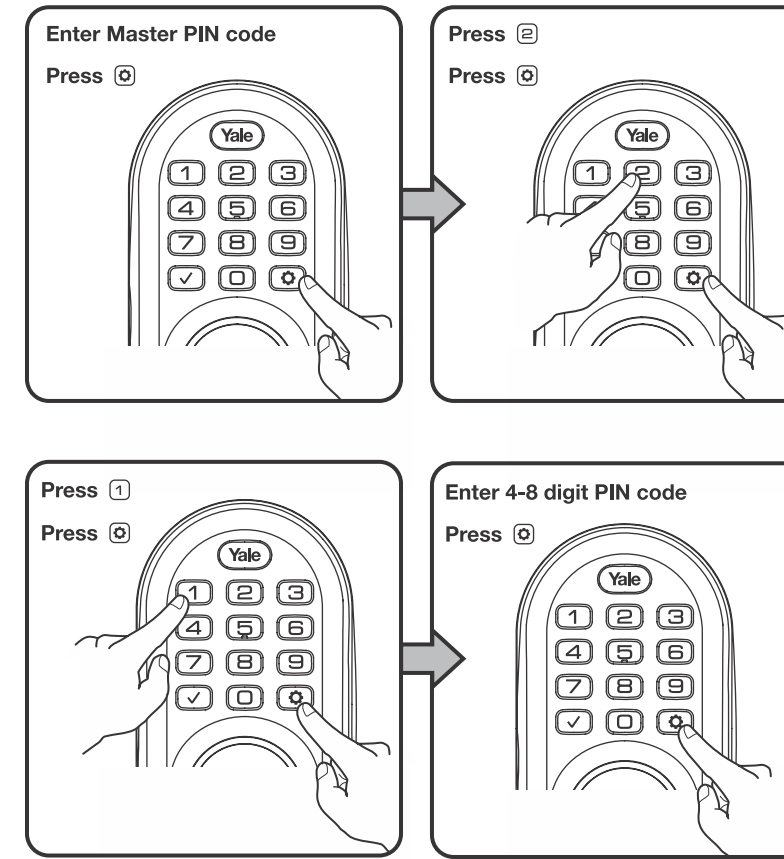

3 Unlocking Door with PIN Code

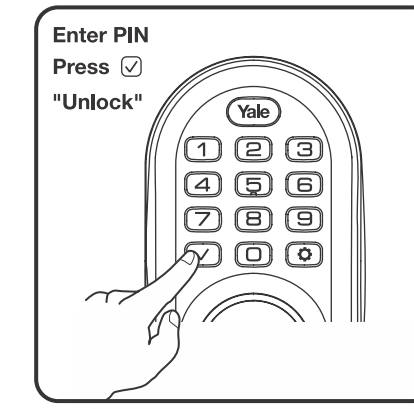

Code Chart Duplicate if necessary

PIN Code Management (With Network Module - Up to 250 Users)			
User Type	User Name	User #	PIN Code
Master			
User ___			
User ___			
User ___			
User ___			
User ___			
User ___			
User ___			
User ___			
User ___			
User ___			
User ___			
User ___			
User ___			
User ___			
User ___			
User ___			
User ___			
User ___			
User ___			
User ___			
User ___			
User ___			

Resetting Lock to Factory Default

When lock is reset to factory defaults all user codes (including the Master PIN code) are deleted and all programming features are reset to original default settings (see below).

- Remove the battery cover and batteries.
- Remove the interior escutcheon to access the reset button.
- The reset button (see image at right) is located beside the PCB cable connector.
- While pressing the reset button (minimum of 3 seconds) reinstall batteries. Release reset button.
- Replace battery cover.

Upon reset, Master PIN Code creation is the only option available and must be performed prior to any other programming of the lock.

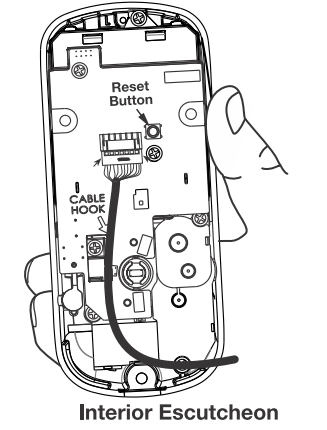

Factory Settings

Settings	Factory Setting
Master PIN Code	Registration <i>required*</i>
Automatic Re-lock	Disabled
Inside Indicator Light	Disabled (Off)
One Touch Locking	Enabled
Privacy Button Setting	Disabled
Audio Mode	Enabled
Lockout Mode	Disabled
Automatic Re-lock Time	30 Seconds
Wrong Code Entry Limit	5 Times
Shutdown Time	60 Seconds

*The Master PIN code must be registered prior to any other programming of the lock.

Definitions

All Code Lockout Mode: This feature is enabled by the Master code. When enabled, it restricts all user (except Master) PIN code access. When attempting to enter a code while the unit is in Lockout, the keypad flashes 8 times and the lock beeps 3 times as well.

Audio Mode: Choosing **Disable (3)** in Audio mode shuts off the code confirmation tone play-back for use in quiet areas. Audio mode is enabled or disabled through feature programming by the Master code.

Automatic Re-lock Time: After a successful unlock, the unit will automatically re-lock after thirty (30) seconds.

Low Battery: When battery power is low, the Status Indicator flashes RED. If battery power is completely lost, use the key override.

Master PIN Code: The Master PIN code is used for programming and for feature settings. It must be created prior to programming the lock. The Master code will also operate (unlock/lock) the lock.

Network Module Setting: This setting is available thru the main Menu (7) and allows the lock to connect with a network controller. It is also available through the wireless button on the interior escutcheon.

One Touch Locking: When the latch is retracted, activating the keypad will extend the latch (during Automatic Re-lock duration or when Automatic Re-lock is disabled).

Privacy Mode: Privacy mode is disabled by default. Enable Privacy mode by pressing the privacy button for 4 seconds to put the lock in do-not-disturb mode (all pin codes are disabled).

Shutdown Time: The unit will shut down (flashing keypad) for sixty (60) seconds and not allow operation after the wrong code entry limit has been met.

Tamper Alert: Audible alarm sounds if attempting to forcibly remove outside lock from door.

User PIN Code: The User code operates the lock. Maximum number of user codes is 250 with Network Module; without Network Module, maximum is 25 user codes.

Wrong Code Entry Limit: After five (5) unsuccessful attempts at entering a valid PIN code, the unit will shut down and not allow operation.

Feature Programming Through Menu Mode Using Master PIN code*

- Enter the 4-8 digit Master PIN code followed by the [M] key.
- Enter digit corresponding to the function to be performed followed by the [0] key.

*The Master PIN code must be registered prior to any other programming of the lock.

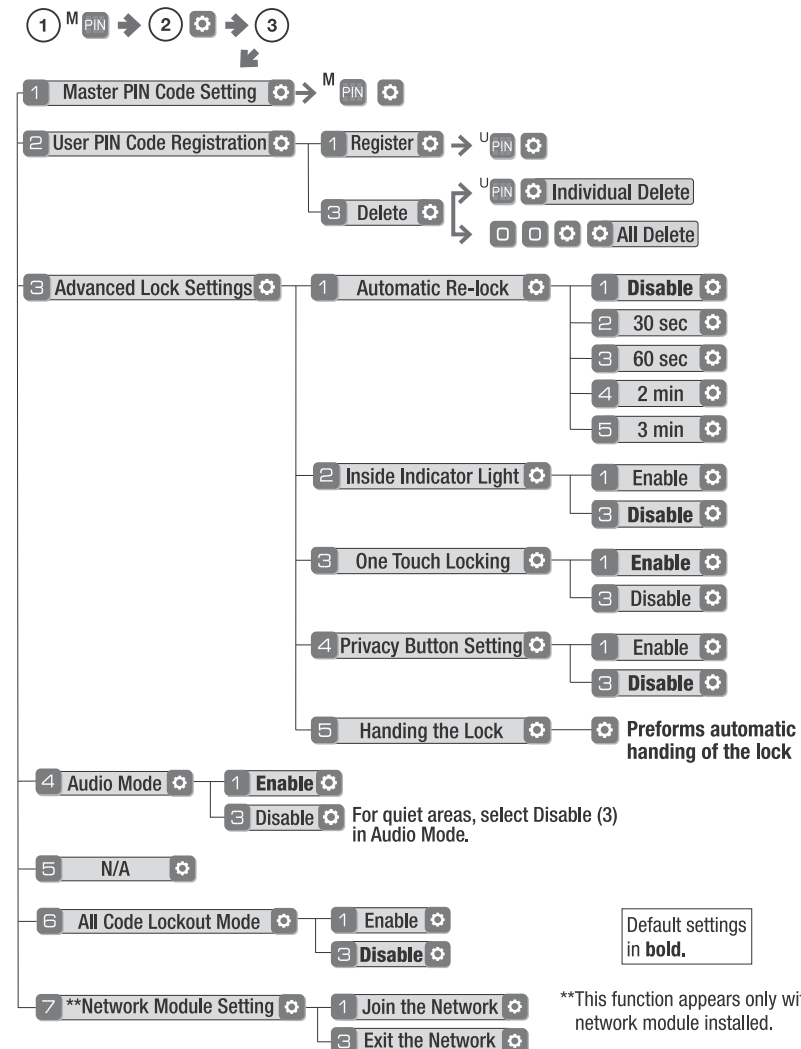

Programming Troubleshooting

Symptom	Suggested Action
Lock does not respond - door is open and accessible.	<ul style="list-style-type: none"> Press each keypad button for response when pressed. Check batteries are installed and oriented correctly (polarity) in the battery case. Check batteries are in good condition; replace batteries* if discharged. Check to see if cable is fully connected and not pinched.
Lock does not respond - door is locked and inaccessible.	<ul style="list-style-type: none"> Batteries may be completely discharged. Use key to gain entry and replace batteries*.
Unit chimes to indicate code acceptance, but the door will not open.	<ul style="list-style-type: none"> Check to see if there is another locking device on the door. Check the door gaps for any foreign objects between door and frame. Check that the cable is firmly connected to the PC board.
Unit operates to allow access, but will not automatically re-lock.	<ul style="list-style-type: none"> Check to see if Auto Re-lock Mode is enabled. If low battery indicator is lit (see below), change batteries*.
PIN codes will not register.	<ul style="list-style-type: none"> PIN codes must consist of 4 to 8 digits to register. The same PIN code cannot be used for multiple users. Registration/management of PIN codes is set by the authority of the Master Code. Contact the Master user. User codes must be entered within 5 seconds or the process will have to be restarted. Check mark [✓] or gear [⚙] cannot be used as part of the PIN code.
Upon entering a PIN code and pressing the [✓] key, the lock gives a series of beeps, flashes red & blue LEDs 7 times, and does not unlock.	<ul style="list-style-type: none"> All Code Lockout Mode is enabled. Only the Master can enable/disable All Code Lockout Mode. Contact the Master user.
Upon entering a PIN code and pressing the [✓] key, there are different tones.	<ul style="list-style-type: none"> Check to see if the lock is set to All Code Lockout Mode. Setting/managing All Code Lockout Mode is done through Master Code only. Contact the Master user.
The unit operates, but it makes no sound.	<ul style="list-style-type: none"> Enable Audio Mode.
The unit displays intermittent RED flashes.	<ul style="list-style-type: none"> This is the Low Battery indicator alerting that it is time to replace the batteries. Replace all four (4) batteries* with new AA Alkaline batteries.
Upon entering a PIN code and pressing the [✓] key, the unit responds with a series of beeps and the keypad flashes three times.	<ul style="list-style-type: none"> The digits entered were incorrect or incomplete. Re-enter the correct code followed by the check mark [✓] key.

*When batteries are replaced, Network locks have a real time clock that will be set through the User Interface (UI); it is recommended to verify correct date and time particularly those locks operating under Daylight Saving Time (DST).

Hardware Troubleshooting

Cycle lock in both the locked and unlocked positions. If problems are found:

Door is binding	<ol style="list-style-type: none"> Check that door and frame are properly aligned and door is free swinging. Check hinges: They should not be loose or have excessive wear on knuckles.
Bolt will not deadlock	<ol style="list-style-type: none"> Check for sufficient clearance of the bolt within the strike-side jamb. Correct this by increasing the depth of the pocket for the bolt. Check for misalignment of bolt and/or strike which may be preventing bolt from properly entering the strike. With the door open, extend and retract the bolt; if it is smooth, check the strike alignment.
Bolt does not extend or retract smoothly	<ol style="list-style-type: none"> Bolt and strike are misaligned, see above. Check the backset of door relative to adjustments already made to bolt. Verify proper door preparation and re-bore holes that are too small or misaligned. Verify keypad wire harness is routed under the bolt (see Fig. A). Verify bolt is installed with correct side up (Fig. A).

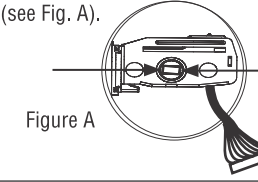

Keypad numerics are scrolling
Remove interior escutcheon and check to ensure that the wire harness lies flat against the back recessed area and is properly routed along the side of the escutcheon and tucked under the plastic cable guide.

Changing Lock: Replacing Cylinder

- To Remove cylinder:
 - Remove outside escutcheon from door.
 - Remove rubber gasket.
 - Remove two screws holding plastic guide in place.
 - Remove plastic guide.
 - Remove screw with washer holding cylinder in place (visible after removing plastic guide).
 - Remove cylinder housing by pulling cylinder tailpiece away from escutcheon.
- To install new cylinder:
 - Reverse previous steps for removing cylinder.

Before installing cylinder, be sure tailpiece is correct length (see below).

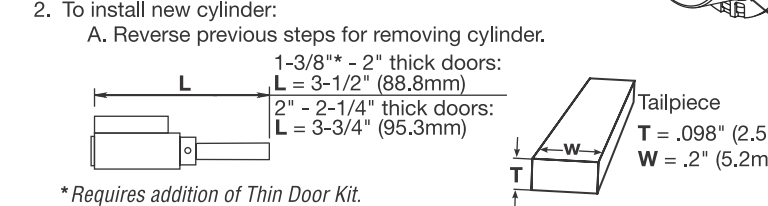

*Requires addition of Thin Door Kit.

Warning: Changes or modifications to this device, not expressly approved by Yale Security Inc. could void the user's authority to operate the equipment.

Industry Canada: This Class A digital apparatus meets all requirements of the Canadian Interference Causing Equipment Regulations. Cet appareil numérique de la classe A répond à toutes les exigences de l'interférence canadienne causant des règlements d'équipement.

Yale Locks & Hardware

Product Support Tel 800.810.WIRE (9473) • www.yalelocks.com
Yale Locks & Hardware is a division of Yale Security Inc., an ASSA ABLLOY Group company.

Yale® and Yale Real Living® are registered trademarks of Yale Security Inc., an ASSA ABLLOY Group company.
Copyright © 2016, Yale Security Inc., an ASSA ABLLOY Group company. All rights reserved. Reproduction in whole or in part without the express written permission of Yale Security Inc. is prohibited.

YALE, with its unique global reach and range of products, is the world's favorite lock - the preferred solution for securing your home, family and personal belongings.

ASSA ABLLOY is the global leader in door opening solutions, dedicated to satisfying end-user needs for security, safety and convenience.