

Duplex Receptacle - Receiver

XPR

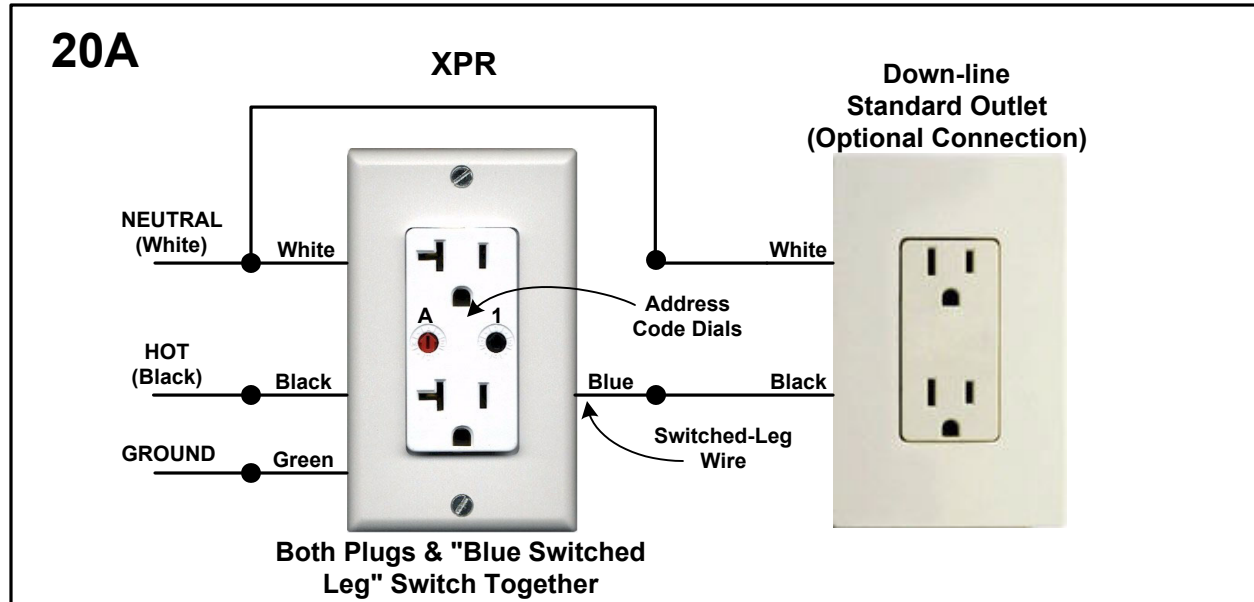

Description: The XPR, 20A Duplex Receptacle is used as a Remote Load Switching Module, which responds to X10 ON/OFF Commands from an X10 PRO Controller. Loads may be plugged into either one of the top/bottom receptacles or hard-wired from the Blue Switched Leg Wire to external loads or down-line receptacles.

Note: LOCAL CONTROL; The XPR Module can "Sense" if any load is plugged into it. When the load on/off switch is toggled to the On position, the Module responds by turning ON the load connected to it. Total load(s) must not exceed 20A.

Specific Requirements: 120VAC, 20A.
Minimum Load = 40W Lamps/Loads rated below 40W may flicker and/or operate erratically.

Optional / Supplementary Devices & Modules:

Down-line Standard Receptacle
PMC01 Desk-top, Plug-in Mini-Controller, PHk05 RF Wireless Handheld Remote Kit, XPMT1 Desk-top, Plug-in Mini-Timer.

X10 Protocol:

House Code Dial - Letters A-P, Default "A" **Unit Number Dial** - Numbers 1-16, Default "1"
Each X10 Receiver Module is set to a unique Unit Number or to an identical Unit Number as desired.
Each X10 Controller operating a specific set of Receiver Modules must be set to the same House Code as the Receivers they are controlling.

Electrical Protocol:

Nearly all residential homes are wired SPLIT-PHASE. Each 120V Phase is NOT directly connected with the other 120V phase. If after installation, an X10 Receiver does not respond to a remote Controller, then check to ensure that the breaker serving the X10 Receiver is on the same phase as the Controller. If not, the breaker can be changed to the opposite phase. An alternative solution is recommended, to install a Phase Coupler for improving remote communications throughout the home. See www.x10pro.com, then select Technical Support and PLC Troubleshooting.

Setting the XPR Address Code:

Using a small screwdriver set the House Code Wheel (RED) to the setting that matches an X10 PRO controller (A-P). Then Set the Unit Code Wheel (BLACK) to the desired number address (1-16).

Installation:

1. Shut off power at the circuit breaker.
2. In a single gang box or approved work box, identify the 120V HOT wire (Black), the White Neutral wire and Green wire (or bare copper) ground.
3. Connect the Green (Ground) wire from the XPR to the Green or Bare Copper Ground wire in the box.
4. Connect the White wire from the XPR to the White Neutral wire.
5. Connect the Black wire from the XPR to the Black HOT wire.
6. Connect the Blue (Switched) wire to a hard-wired load or down-line receptacle (if not desired, cap and securely tape the Blue wire).
7. Check that all connections are tight and no bare conductors are exposed.
8. Mount the XPR to the junction Box and attach the wall plate.
8. Restore power.
9. Plug the device into the either top/bottom outlets on the XPR and make sure the switch (if the device has one) is in the ON position.
10. Send an X10 ON/OFF Command to the XPR and it will operate your plugged in device remotely.