

# Kwikset



## SMARTCODE 916

TOUCHSCREEN ELECTRONIC DEADBOLT



SmartCode 916 Awards



Electronic House:  
Product of the  
Year 2015



Connected World:  
IoT Innovations  
Award 2015



TWICE:  
VIP Award  
2015



Chicago Athenaeum:  
Good Design Award  
2015

The SmartCode 916 features a capacitive touchscreen with Kwikset's patented SecureScreen™ technology to prevent code detection from fingerprints on the touchscreen. The traditional design complements homes with a classic or transitional décor.

### Features

- 10 digit capacitive touchscreen with one touch locking
- Motorized deadbolt - enables true remote locking and unlocking
- SecureScreen™ - helps to ensure user codes cannot be identified by examining fingerprints on screen
- Sleek metal design for enhanced quality

### User Codes

- Up to 30 customizable user access codes for family & guests
- Mastercode feature for improved user access code management

### Connected Benefits

- Lock & Unlock your doors from anywhere
- View lock status and receive notifications of your lock's activity
- Connect to other devices in the home and create scenes driven by the door lock

*Consult your system provider to learn more about your connected benefits*

THE LEADER IN RESIDENTIAL SECURITY

## Specifications

<b>Function</b>	Single Cylinder Deadbolt
<b>Door Prep</b>	2 1/8" diameter face hole & 1" diameter latch hole
<b>Backset</b>	Adjustable 2 3/8" or 2 3/4"
<b>Door Thickness</b>	1 3/8" - 2 1/8" automatic adjustment
<b>Cylinder</b>	SmartKey® Re-key Technology
<b>Faceplates</b>	1" x 2 1/4" round corner standard
<b>Strikes</b>	Round corner strike 2 3/4" x 2 1/8"
<b>Latch</b>	Round corner adjustable 2 3/8" x 2 3/4"
<b>Bolt</b>	1" throw, steel deadbolt
<b>Door Handing</b>	Reversible
<b>Wireless Protocol</b>	Z-Wave 500; lock complies with Z-Wave standard of open air, line of sight transmission of 160 feet or more. Compliant with FCC Part 15, Industry Canada.  *Range may vary depending on radio frequency environment. Work with your home control platform to optimize range

## Easy Installation

- Replaces existing door hardware with just a screwdriver
- No hard wiring needed
- Operates on 4 AA batteries that will last for approximately 1 year

## Finishes



**99160-020**  
916TRL ZW500 15 RCALFD  
Satin Nickel **15**



**99160-021**  
916TRL ZW500 11P RCALFD  
Venetian Bronze **11P**



**99160-019**  
916TRL ZW500 L03 RCALFD  
Polished Brass **L03**

FINISH AND  
**LIFETIME WARRANTY**  
MECHANICAL  
  
ONE YEAR  
ELECTRONIC WARRANTY



## Dimensions

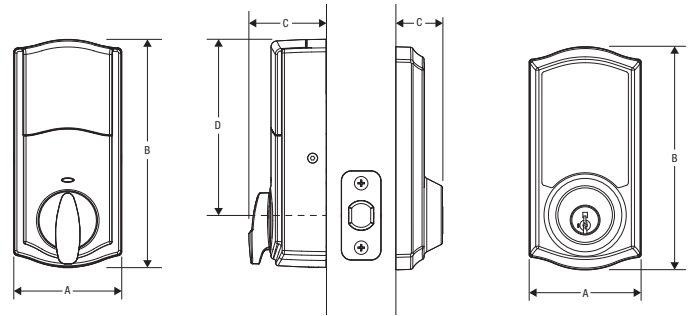

Design	A	B	C	D
Interior	2 3/4" (70 mm)	5 3/4" (146 mm)	1 15/16" (49 mm)	4 9/16" (116 mm)
Exterior	2 13/16" (72 mm)	5 5/8" (143 mm)	1 3/16" (30 mm)	---

## Innovative Security

- BHMA Grade 2 certified
- 20 Minute fire rating - UL certified
- Full 128-bit encryption security
- Featuring SmartKey Security™
- Revolutionary tapered deadbolt design—enables misaligned doors to lock without pulling and pushing your door shut

# Kwikset

kwikset.com/wirelesslocks • 866-863-6584 • connected@kwikset.com

© 2017 Spectrum Brands, Inc. Kwikset is a trademark of Spectrum Brands, Inc. Lake Forest, CA 92610 • 92866-KW