



Always Connected. Always Covered.

Door/Window Sensor

DMDP1



User Manual

Preface

As this is the full User Manual, a working knowledge of Z-Wave automation terminology and concepts will be assumed. If you are a beginner user, please visit www.domeha.com for instructions. This manual will provide in-depth technical information about the Door/Window Sensor, especially in regards to its compliance to the Z-Wave standard (such as compatible Command Classes, Association Group capabilities, special features, and other information) that will help you maximize the utility of this product in your system.

Table of Contents

| | |
|--|----|
| Preface..... | 2 |
| Description & Features..... | 4 |
| Specifications..... | 5 |
| Physical Characteristics | 6 |
| Inclusion & Exclusion..... | 7 |
| Physical Installation..... | 9 |
| LED Behavior | 11 |
| Button Behavior..... | 12 |
| Compatible Command Classes..... | 13 |
| “Configuration” Command Class Parameters | 16 |
| Troubleshooting..... | 19 |
| Warranty & Support..... | 20 |

Description & Features



The Dome Door/Window Sensor is a battery powered security-enabled* Z-Wave Plus magnetic reed switch that can monitor the status of doors, windows, and anything else that opens and closes. It can also report ambient temperature levels. The Door/Window Sensor consists of two parts - the "sensor," and the "magnet." The sensor has a "reed switch" inside, which is sensitive to the magnet's presence when aligned properly and within the defined distance. When the sensor and magnet are brought together or pulled apart, the sensor will report its open/close status to its Z-Wave controller, and the encrypted wireless communication* ensures that user data remains secure. Because many manufacturers use Z-Wave to communicate, the Door/Window Sensor can interact with different products of different categories.

Key Features:

- » Z-Wave Plus Certified
- » S0 Security-Enabled*
- » Built-In Temperature Sensor
- » Up to 250' range
- » Ten-Year Battery Life
- » LED Signal Strength Indication
- » 1.25" Max distance between sensor & magnet
- » Ultra-Narrow (1/4") Magnet for Placement Between Door and Casing
- » Monitor doors, windows, medicine cabinets, drawers, garage doors, and many other openings

*A security-enabled Z-Wave Plus controller is required to use all features of the Door/Window Sensor.

Specifications

Technical Specifications

| | |
|------------------------|---|
| Radio protocol | Z-Wave(500 series) |
| Power supply | Single ER14505 (AA) 3.6V battery |
| Standby current | 7uA |
| Working current | 35mA |
| Operating temperature | 32 - 104 °F (0 - 40 °C) |
| Radio frequency | 908.4 MHz US |
| Range | Up to 250' depending on environment |
| Dimensions (L x W x H) | Sensor: 2.9" x 0.85" x 0.87" (75 x 21 x 22 mm) Magnet: 1.6" x 0.25" x 0.5" (40 x 6.35 x 12 mm) |

Table 1 - Technical Specifications

Package Contents:

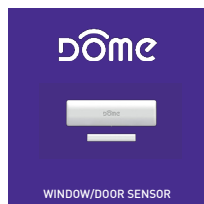

User Manual

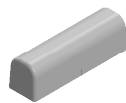

Sensor



Magnet



Battery



4x Screws



4x Wall Anchors

Physical Characteristics

The names used in Figures 1 & 2 will be used throughout this manual. Please refer to this page as needed.

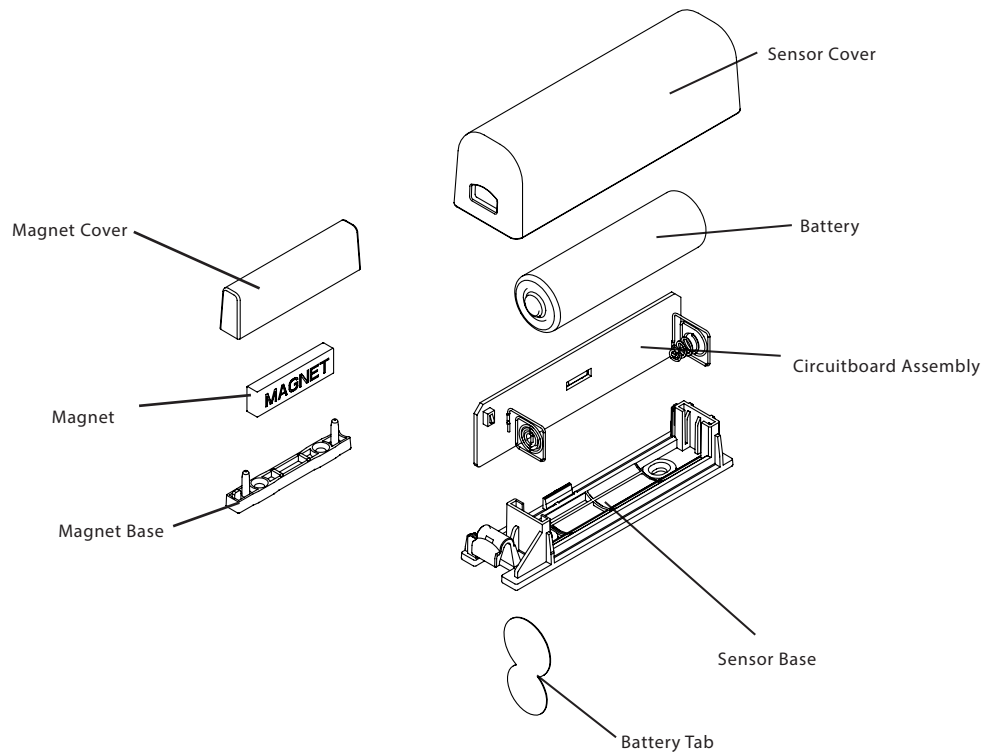

Figure 1 - Exploded View

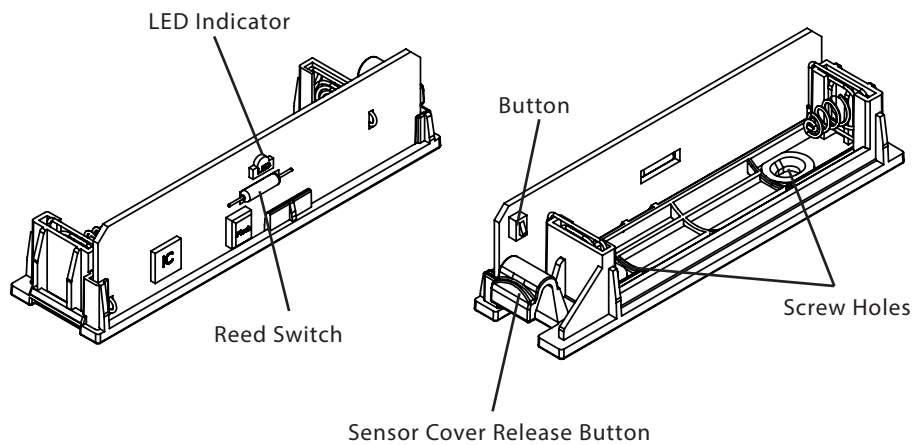

Figure 2 - Main Parts of the Door/Window Sensor

Inclusion & Exclusion

Inclusion (Add to System)—New Installation

1. For proper inclusion, bring the Door/Window Sensor to the final location where it will be used*.
2. Follow the instructions for your Z-Wave controller to enter inclusion mode.
3. Remove the Battery Tab protruding from the Battery Tab Slit.
4. The device will automatically enter inclusion mode for two minutes and the LED Indicator will alternate between green and red.

Upon successful inclusion the LED Indicator will flash green three times then stop blinking.

Inclusion (Add to System) —Re-Installation

1. For proper inclusion, bring the Door/Window Sensor to the final location where it will be used*.
2. Follow the instructions for your Z-Wave controller to enter inclusion mode.
3. Remove the Sensor Cover and the LED Indicator will start blinking yellow.
4. Press the Button quickly 3 times in a row.
5. The device will enter inclusion mode for two minutes and the LED Indicator will alternate between green and red.

After successful inclusion, the LED Indicator will flash green three times then blink red until the cover is replaced.

Exclusion (Remove from System)

Follow the instructions for your Z-Wave Certified Controller to enter exclusion mode. When prompted by the controller:

1. Remove the SENSOR COVER and the LED Indicator will start blinking red.
2. Press the Button quickly 3 times in a row.

The LED Indicator will flash green three times indicating exclusion/disconnection and will then continue flashing red (indicating tamper) until the cover is replaced.

*For non Z-Wave Plus networks, please consult the owner's manual for your primary controller to determine the best method and location for adding the Door/Window Sensor to your Z-Wave network.

Resetting the Door/Window Sensor

If needed, the Door/Window Sensor can be reset locally by following these steps. **Only do this if your Z-Wave controller is missing or otherwise unreachable.** Beware that resetting your device will disconnect it from the system:

1. Remove the Sensor Cover and confirm that your Door/Window Sensor is powered up.
2. Wait for 5 seconds.
3. Move the Magnet and Sensor Base in and out of the closed position 6 times.
4. The LED Indicator will light up red for five seconds when reset successfully. The Door/Window Sensor's memory will be erased to factory settings.

Waking Up The Door/Window Sensor

Because the Door/Window Sensor is a battery powered device, it wakes up on regular intervals to give battery and other status updates to the controller, as well as to accept configuration settings from the controller. This helps to extend the battery life. The Sensor Cover holds down the Button when installed, and the device can be forced to wake up to submit reports or accept new settings immediately by simply removing the Sensor Cover and then replacing it after. If the device is already included in a system, the LED Indicator will flash Red until the cover is closed.

Physical Installation

The Door/Window Sensor can be secured with the pre-applied double stick tape or the provided hardware. The device should already be included in your Z-Wave system before continuing further.

Pre-Installation Checklist

- ✓ The Magnet Assembly and Sensor Assembly should be less than 1-1/4" apart when closed (Figure 3.)
- ✓ Hold the Magnet Assembly and Sensor Assembly in place by hand where you wish to install them, move them in and out of the closed position, and make sure the LED Indicator blinks in response. This will confirm that the door and frame are spaced correctly to accommodate the sensor.
- ✓ When moving the Magnet and Sensor in and out of the closed position, a Green followed by another Green or Red LED Indicator corresponds to Excellent or Poor Z-Wave Signal strength respectively.
- ✓ Make sure the Sensor Cover Release Button will be accessible in the final position.
- ✓ The Magnet is small enough (only 1/4" wide) to fit in the groove between the door and the casing.
- ✓ Finally, confirm that you are still within range of your Z-Wave controller.

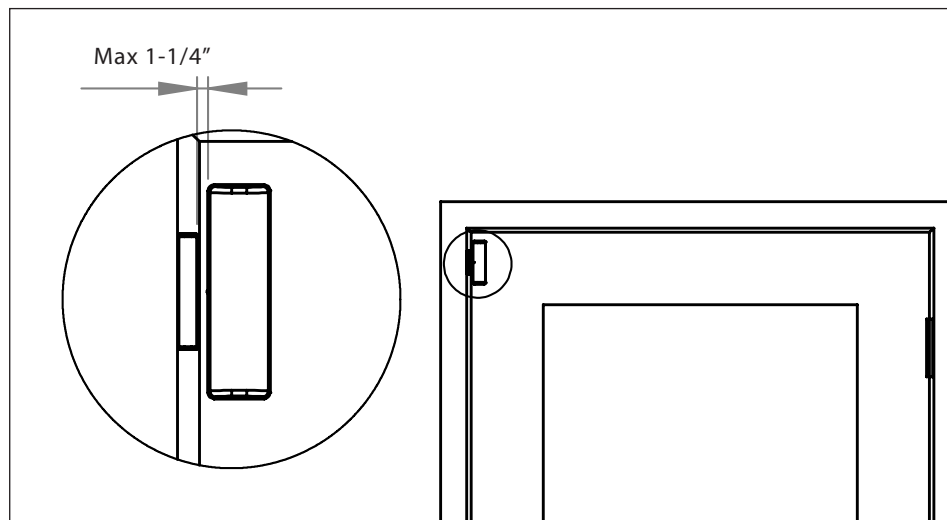

Figure 3 - Placing the Door/Window Sensor on the Door

Installation Using Double-Stick Tape

1. Wipe the door and door-frame clean of dust and anything else that will interfere with the tape's stickiness.
2. Peel the double-stick tape and adhere the Sensor Assembly to the door surface.
3. Repeat the process for the Magnet Assembly, making sure the Magnet Assembly, and Sensor Assembly are no more than 1-1/4" apart when closed. The lines on the sides of the Magnet Assembly, and Sensor Assembly should be in line.
4. Open and close the door to make sure the sensor works as expected (the LED Indicator blinks) and that the signal reaches your Z-Wave controller.

Installation Using Screws

1. Remove the Sensor Cover and Battery from the Sensor Base and the Magnet Cover from the Magnet Base.
2. Hold the Sensor Base in place and drive the included screws through the screw holes into the door.
3. Repeat the process for the Magnet Assembly, making sure the Magnet Assembly, and Sensor Assembly are no more than 1-1/4" apart when the door is closed. The lines on the sides of the MAGNET and SENSOR should be in line.
4. Replace the Battery, Sensor Cover, and Magnet Cover.
5. Open and close the door to make sure the sensor works as expected (the LED Indicator blinks) and that the signal reaches your Z-Wave controller.

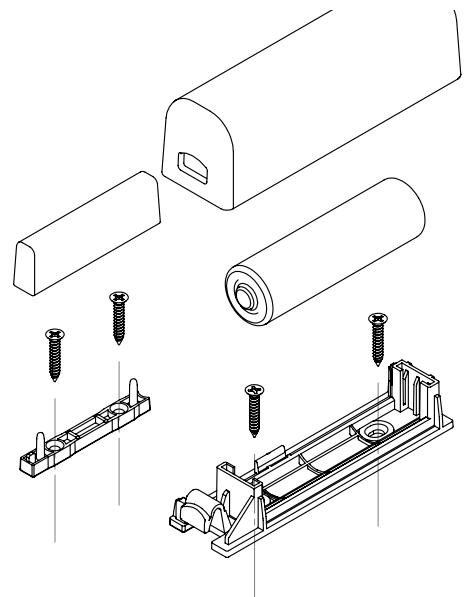

Figure 4 - Screw Alignment

LED Behavior

| Color | Behavior | This happens when... |
|----------------------|--|---|
| Green | Blinks Twice Within 5 Seconds | ...the sensor Detects the Magnet moving away or getting close (as the Door is opened or closed) and Z-Wave signal strength is high. |
| | Blinks 3 times quickly | ...the device is successfully included into the system. |
| Red | Stays on for 5 seconds | ...the device is reset to factory settings. |
| | Blinks 3 Times quickly | ... the Button is pressed 3 times quickly and the device is excluded from the network. |
| | Blinks indefinitely | ...the Sensor Cover is removed and the device is already included in a system. |
| Yellow (Green + Red) | Blinks Indefinitely | ...the Sensor Cover is removed and the device is not yet included in a system. |
| Red & Green | Two Flashes (Green-Red) Within 5 Seconds | ...the sensor Detects the Magnet moving away or getting close (as the Door is opened or closed) and the Z-Wave signal was not received. |
| | Flashing in alternating colors | ...the Door/Window Sensor is in inclusion mode. It will continue blinking and remain in inclusion mode for up to two minutes, until it is included in a system. |

Table 2 - LED Blinking Behavior

Button Behavior

| Action | Condition | Result |
|---|--|--|
| Open the Cover | Door/Window Sensor Not Yet Included in System | LED Indicator blinks yellow (red + green) until the Sensor Cover is replaced |
| | Door/Window Sensor Already Included in System | Device sends a tamper notification to its controller, awaits further instructions, and the LED Indicator blinks red until the Sensor Cover is replaced |
| Open the Cover, then Replace it | Door/Window Sensor Already Included in System | Device sends a wake up notification to the main controller and awaits further instructions. |
| Push Button 3 Times | Door/Window Sensor Already Included in System | Device sends node info to Group 1 |
| | Door/Window Sensor Already Included, and Controller is in Exclusion Mode | Device is excluded from the system and removes the Home ID from its memory |
| | Door/Window Sensor Not Yet Included in System, and Controller is in Inclusion Mode | Device enters inclusion mode and includes into whichever network is also in inclusion mode |
| Move the Magnet and Sensor In and Out of the Closed Position 6 Times with Cover Removed | Door/Window Sensor Already Included in System | Device will be reset to factory settings, and a DEVICE_RESET_LOCALLY command will be sent to Group 1 |
| | Any condition (as long as the device has power) | The device's memory will erase to factory default settings and any associations, configuration parameters, and other locally saved data will be lost |

Table 3 - Button Behavior

Compatible Command Classes

| Command Class | Notes |
|---------------------------------------|--|
| Device Reset Locally V1 (5A) | - |
| Powerlevel V1 (73) | - |
| Battery V1(80) | - |
| Association Group Information V1 (59) | - |
| Z-Wave Plus Info V2 (5E) | <p>Returned Value: 01 06 00 0C 06 0C 06</p> <p>Z-Wave Plus Version: 01 Role Type: 06 (<i>Slave Sleeping Reporting</i>) Node Type: 00 (<i>Z-Wave Plus Node</i>) Installer Icon Type: 0C 06 (<i>Access Control Alarm</i>) User Icon Type: 0C 06 (<i>Access Control Alarm</i>)</p> |
| Version V2 (86) | <p>Returned Value: 03 04 21 01 11 1E 00</p> <p>Z-Wave Library Type: 03 (<i>Enhanced Slave</i>) Protocol Version: 04 21 Protocol Sub-Version: 01 11 Application Version: 1E Application Sub-Version: 00</p> |
| Manufacturer Specific V2 (72) | <p>Returned Value: 02 1F 00 03 02 01</p> <p>Manufacturer ID: 02 1F Product Type: 00 03 Product ID: 02 01</p> |
| Binary Sensor (30) | <p>If Configuration Parameter 3 is set to 01, the Door/Window Sensor sends a Binary Sensor Report when opened or closed and also when tamper events are detected. See below for the SENSOR_BINARY_REPORT parameters sent:</p> <p>Sensor Type: 0A (<i>Door/Window</i>) OPEN Value: FF CLOSE Value: 00 Sensor Type: 08 (<i>Tamper</i>) Tamper Detected Value: FF No Tamper Detected Value: 00</p> |

Table 4 - Command Classes

| Command Class | Notes |
|---------------------|--|
| Association V2 (85) | <p>Group 1 Group 1 is the “Lifeline” group, which can hold five members, typically including the main Z-Wave controller. The Door/Window Sensor sends this group a Notification Report or a Binary Sensor Report when it is opened or closed (see Configuration Parameter 3.) It also sends this group a multilevel sensor report to report the temperature (if Configuration Parameter 4 is set to 01) and a Battery Report in response to Battery Get commands.</p> <p>Group 2 Group 2 supports up to 5 members and the Door/Window Sensor sends a Basic Set command to this group (or the Control Group) to directly trigger devices (like a light, chime, etc.) when the tamper switch either opens or closes. The value of the Basic Set command (e.g. brightness of the lamp) is configured using configuration parameter 07.</p> <p>Group 3 Group 3 supports up to 5 members and the Door/Window Sensor sends it a NOTIFICATION_REPORT or SENSOR_BINARY_REPORT when the tamper switch either opens or closes.</p> <p>Group 4 Group 4 supports up to 5 members and the Door/Window Sensor sends a Basic Set command to this group to directly trigger devices (like a light, chime, etc.) when the sensor detects the door/window opening or closing. The value of the Basic Set command (e.g. brightness of the lamp) is configured using configuration parameters 08 and 09.</p> <p>Group 5 Group 5 supports up to 5 members and the Door/Window Sensor sends it a NOTIFICATION_REPORT or SENSOR_BINARY_REPORT when the sensor detects the door/window opening.</p> |
| Wake Up V2 (84) | The wake-up interval is set in minutes, and is 120 minutes (two hours) by default. The wake-up interval can be set to any value from 1 min up to 10,080 min (7 days) in 1-min increments. |

Table 5 - Command Classes Continued

| Command Class | Notes |
|------------------------|--|
| Notification V4 (71) | <p>If Configuration Parameter 3 is set to 00, the Door/Window Sensor sends a Notification Report to the main controller whenever the door is opened and closed and also when tamper events are detected. Two different Notification Types are used to achieve this.</p> <p style="text-align: center;">Returned Value: 00 00 00 FF XX XX 00 00</p> <p>V1 Alarm Type: 00 (<i>Unsupported</i>) V1 Alarm Level: 00 (<i>Unsupported</i>) Reserved: 00 (<i>Reserved</i>) Notification Status: FF (<i>Unsolicited Reporting is Enabled</i>) Notification Type: Door—06 (<i>Access Control</i>) Tamper—07 (<i>Home Security</i>) Event: Door Open—16 (<i>Window/Door is Open</i>) Door Closed—17 (<i>Window/Door is Closed</i>) Tamper Detected—03 (<i>Tampering, Product Covering Removed</i>) No Tamper Detected—00 (<i>Event Inactive</i>) Sequence/Reserved/Event Parameters Length: 00 Notification Event Parameters: 00 (<i>No Event Parameters</i>)</p> |
| Multilevel Sensor (31) | <p>The Door/Window Sensor monitors ambient temperature levels and reports this data to the main controller using the Multilevel Sensor command class if Configuration Parameter 04 is set to 01 (this is off by default.) Configuration Parameter 05 is used to “offset” the reported value (add or deduct a static number from the reported value) and Configuration Parameter 06 switches between Celsius and Fahrenheit.</p> <p style="text-align: center;">Returned Value: 01 XX XX</p> <p>Sensor Type: 01 (<i>Temperature</i>) Precision/Scale/Size: Celsius—01 (<i>Precision = 000; Scale = 00; Size = 001</i>) Fahrenheit—09 (<i>Precision = 000; Scale = 01; Size = 001</i>) Sensor Data: 00 ~ FF (<i>0 ~ 255 in Degrees Fahrenheit or Celsius</i>)</p> |
| Configuration V1 (70) | See ““Configuration” Command Class Parameters” on page 16. |

Table 6 - Command Classes Continued

“Configuration” Command Class Parameters

Configuration parameters are sent using a standard syntax to ensure interoperability between all manufacturers’ products. All values are represented using the hexadecimal number system.

Typical syntax is as shown below. Note that the value sent must be the exact size, in bytes, as accepted by the setting. The “extra” spaces should be filled with zeros (see the “value” column below.)

Example Configuration Parameter: 02 02 00 0A

| Param # | Size | Value |
|-------------------------|------------------------|----------------------|
| 02 <i>(Param #2)</i> | 02 <i>(2 Bytes)</i> | 00 0A <i>(10)</i> |

| Param # | Size | Name | Available Values | Default Value |
|---------|---|-----------------------------------|--|--|
| 01 | This parameter enables or disables the LED Indicator flashing to indicate opening and closing events. The Door/Window Sensor will always flash the LED Indicator for inclusion, exclusion, tamper, and other system events. | | | |
| | 01 | Enable/Disable LED Indicator | 00 <i>(Open/Close LED Indicator Disabled)</i> 01 <i>(Open/Close LED Indicator Enabled)</i> | 01 <i>(Open/Close LED Indicator Enabled)</i> |
| 02 | This parameter switches the Notification or Binary Sensor report sent when the door opens or closes. If this parameter is set to 01, the Door/Window Sensor will report “closed” instead of “open” when the Magnet and Sensor are pulled apart. | | | |
| | 01 | Configure Open/Close Reports Sent | 00 <i>(Reports Closed when Magnet is close)</i> 01 <i>(Reports Open when Magnet is close)</i> | 00 <i>(Reports Closed when Magnet is close)</i> |

Table 7 - Door/Window Sensor Configuration Parameters

| Param # | Size | Name | Available Values | Default Value |
|---------|---|---|---|--|
| 03 | <p>By default, the Door/Window Sensor uses the Notification command class to communicate open/close and tamper events. If this Parameter is set to 1, the device will instead use the Binary Sensor command class.</p> <p>To apply this setting, the battery needs be removed and replaced! This is because the supported command classes will change according to this setting, so the device must restart to advertise its new command classes.</p> | | | |
| | 01 | Switch Between Notification and Binary Sensor Command Classes | 00 (Notification Command Class is Used) 01 (Binary Sensor Command Class is Used) | 00 (Notification Command Class is Used) |
| 04 | <p>The Door/Window Sensor can also monitor and report ambient temperature conditions. However, temperature sensing functionality is disabled by default to save battery life, and this configuration parameter is used to enable or disable this feature.</p> <p>To apply this setting, the battery needs be removed and replaced! This is because the supported command classes will change according to this setting, so the device must restart to advertise its new command classes.</p> | | | |
| | 01 | Enable/Disable Temperature Sensor | 00 (Temperature Sensor Disabled) 01 (Temperature Sensor Enabled) | 00 (Temperature Sensor Disabled) |
| 05 | <p>This Configuration Parameter can offset the temperature value reported by ± 125 degrees to compensate for temperature variances in a room - for example, the temperature near the ceiling in a room is significantly higher than the average temperature of the same room. This Parameter accepts a signed 8-bit value with an absolute value of up to 125, and its units are Dependant on Configuration Parameter 07</p> | | | |
| | 01 | Temperature Offset | 00~7D (0°~125°) 83~FF (-125°~-1°) | 00 (0° Offset) |

| Param # | Size | Name | Available Values | Default Value |
|---------|--|-----------------------------------|---|--|
| 06 | The Door/Window Sensor can report temperature values in either Celsius or Fahrenheit, and this parameter allows the user to decide which unit is used. | | | |
| | 01 | Temperature Units | 00 (Temperature is Reported in Fahrenheit) 01 (Temperature is Reported in Celsius) | 00 (Temperature is Reported in Fahrenheit) |
| 07 | This parameter sets the value sent by the Basic Set command to Association Group 2. The Door/Window Sensor sends a Basic Set command to Association Group 2 both when the tamper switch opens and closes (for more information, see "Group 2" on page 14.) | | | |
| | 01 | Basic Set Value (Group 2) | 00 (0/Turn Off Device) 01 ~ 63 (0-99) FF (255/Turn On Device) | FF (255/Turn On Device) |
| 08 | This parameter sets the value sent by the Basic Set command to Association Group 4. The Door/Window Sensor sends a Basic Set command to Association Group 4 when the door or window opens (for more information, see "Group 4" on page 14.) | | | |
| | 01 | Basic Set Level (Group 4 Opening) | 00 (0/Turn Off Device) 01 ~ 63 (0-99) FF (255/Turn On Device) | FF (255/Turn On Device) |
| 09 | This parameter sets the value sent by the Basic Set command to Association Group 4. The Door/Window Sensor sends a Basic Set command to Association Group 4 when the door or window closes (for more information, see "Group 4" on page 14.) | | | |
| | 01 | Basic Set Level (Group 4 Closing) | 00 (0/Turn Off Device) 01 ~ 63 (0-99) FF (255/Turn On Device) | 00 (0/Turn Off Device) |

Table 9 - Door/Window Sensor Configuration Parameters

Troubleshooting

Q: Help! My Door/Window Sensor paired successfully, but my controller can't see it anymore after I installed it!

A: First, make sure your battery didn't come loose during set-up. Otherwise, the Z-Wave signal is probably weak in that area of your home. Remember that the 120' - 150' range doesn't take into account walls, furniture, and other obstacles. To boost your Z-Wave network coverage, add a few non-battery powered Z-Wave devices between the controller and the furthest device, like the Dome On/Off Plug or Water Main Shut-Off. You can even purchase dedicated Z-Wave extenders from 3rd party manufacturers.

Q: There's so many words in this manual I don't understand. How can I learn more about Z-Wave?

A: Remember you don't have to understand everything in this manual to start automating your home. Our Quick-Start Guides have all you need to start using any device. For more thorough information about Z-Wave home automation, visit www.domeha.com/support.

Q: My sensor keeps telling me it's open when my door is closed!

A: Your magnet and sensor are probably too far apart. Try remounting one of them closer to the other, and it should start working consistently.

Q: I've tried multiple times, but I can't include the Door/Window Sensor in my system.

A: Check your battery and make sure your device is getting power. Then, follow the instructions under "Factory Reset & Misc. Functions" on page 8 and try going through the inclusion process again. If you are still having issues, please visit www.domeha.com/support

Q: All of a sudden, my Door/Window Sensor is offline.

A: Check your battery and make sure your device is getting power. If powered, make sure you still have Z-Wave network coverage. If you are still having issues, visit www.domeha.com/support.

Warranty & Support

If you have questions, our trained Customer Service Department is happy to assist you 24 hours a day, 7 days a week. Contact Dome Customer Service as follows: • In North America dial: 1-855-249-1754 • Email Dome at support@domeHA.com

DO NOT RETURN THIS PRODUCT TO THE STORE OR WEBSITE FROM WHICH IT WAS PURCHASED

If you believe the product is defective, has a missing or broken part or are having difficulty with it please contact Dome as listed above for a quick and efficient solution to the problem.

Legal Notices: This device complies with part 15 of the FCC rules. Operation is subject to the following two conditions (1) This device may not cause harmful interference, and (2) this device must accept any interference received, including interference that may cause undesired operation.

Note: This equipment has been tested and found to comply with the limits for a Class B digital device, pursuant to part 15 of the FCC Rules. These limits are designed to provide reasonable protection against harmful interference in a residential installation. This equipment generates, uses and can radiate radio frequency energy and, if not installed and used in accordance with the instructions, may cause harmful interference to radio communications.

However, there is no guarantee that interference will not occur in a particular installation. If this equipment does cause harmful interference to radio or television reception, which can be determined by turning the equipment off and on, the user is encouraged to try to correct the

Interference by one or more of the following measures: Reorient or relocate the receiving antenna; increase the separation between the equipment and the receiver; connect the equipment into an outlet on a circuit different from that to which the receiver is connected. Consult the dealer or an experienced radio/TV technician for help.

This device complies with Industry Canada license-exempt RSS standard(s). Operation is subject to the following two conditions: (1) this device may not cause interference, and (2) this device must accept any interference, including interference that may cause undesired operation of the device.

Elexa Consumer Products, Inc. ("ECP") warrants to the original retail purchaser ("Purchaser") that the DOME Window/Door sensor (the "Product") will be free of defects in materials or workmanship under use for one (1) year from the date of purchase (the "Warranty period").

For the Purchaser only, if the Product fails to perform as specified during the Warranty Period due to defective parts or faulty workmanship, ECP will repair or replace the defective or damaged parts of the Product. Normal wear and tear is not covered nor is abnormal use, misuse, mishandling, faulty installation, improper shipping, damage caused by disasters such as fire, flood or earthquake, neglect, accident or tampering. This warranty covers only normal use in the United States or Canada.

To obtain warranty service during the Warranty Period, call Dome Customer Service (1-855-249-1754) or email: support@domeHA.com for instructions on sending damaged parts and documentation for a Return Material Authorization (RMA). Products returned to ECP for repair or replace-

ment without authorization will be returned at the sender's expense. All warranty claims must be accompanied by a legible copy of the original receipt showing date and details of purchase. The RMA number must be clearly written on the side of the shipping container in which you return the Product or defective parts. Unless otherwise instructed by ECP, the Product must be sent freight pre-paid to the following address:

Elexa Consumer Products, c/o Promac,
1153 Timber Dr., Elgin, IL 60123

ECP will repair or replace the defective parts and return them at ECP's cost by a shipping method selected by ECP. When contacting ECP to obtain an RMA, Purchaser may request expedited return shipping at Purchaser's expense.

THIS WARRANTY IS NOT TRANSFERABLE, AND, TO THE MAXIMUM EXTENT PERMITTED BY APPLICABLE LAW IS IN LIEU OF ALL OTHER WARRANTIES, REPRESENTATIONS AND CONDITIONS, EXPRESSED OR IMPLIED, STATUTORY OR OTHERWISE, INCLUDING BUT NOT LIMITED TO THE IMPLIED WARRANTIES OF MERCHANTABILITY AND FITNESS FOR A PARTICULAR PURPOSE. NO OTHER PERSON OR REPRESENTATIVE IS AUTHORIZED TO MAKE ANY OTHER WARRANTY ON BEHALF OF ECP OR ASSUME FOR ECP ANY OTHER LIABILITY IN CONNECTION WITH THE SALE OF THIS PRODUCT. IN NO EVENT WILL ECP BE LIABLE FOR ANY DAMAGES, INCLUDING BUT NOT LIMITED TO INCIDENTAL, SPECIAL OR CONSEQUENTIAL DAMAGES ARISING OUT OF THE USE OR INABILITY TO USE THE PRODUCT, INCLUDING DAMAGES DUE TO ECP'S NEGLIGENCE.

THIS WARRANTY GIVES YOU SPECIFIC LEGAL RIGHTS, AND YOU MAY ALSO HAVE OTHER RIGHTS WHICH VARY FROM STATE TO STATE AND COUNTRY TO COUNTRY.

This marking on the product, accessories or literature indicates that the product and its electronic accessories should not be disposed of with other household waste.

To prevent possible harm to the environment or human health from uncontrolled waste disposal, please separate these items from other types of waste and recycle them responsibly to promote the sustainable reuse of material resources.

Household users should contact either the retailer where they purchased this product, or their government office, for details of where and how they can take these items for Environmentally safe recycling.

Business users should contact their supplier and check the terms and conditions of the purchase contract. This product and its electronic accessories should not be mixed with other wastes for disposal.

This marking on the battery, manual or packaging indicates that the batteries in this product should not be disposed of with other household waste. Where marked, the chemical symbols Hg, Cd or Pb indicate that the battery contains mercury, cadmium or lead above the reference levels in EC Directive 2006/66. If batteries are not properly disposed of, these substances can cause harm to human health or the environment.