

# SW-PIR03N Z-Wave Motion Sensor Installation Guide

SW-PIR03N is a PIR (Passive Infrared) sensor, which can detect levels of infrared radiation from objects in its range of view. This Motion Detector is fully compatible with any Z-Wave controller and can be operated in any Z-Wave network with other Z-Wave certified devices from other manufacturers. All non-battery operated nodes within the network will act as repeaters regardless of vendor to increase reliability of the network."

It is also a pet immune motion sensor, which is used to ignore the motion caused by animals and thus reduce the likelihood of false alarms. The sensitivity of the sensor will disregard the motion caused by animals under 85 pounds, like a full-grown dog or small cats.

In addition, the SW-PIR03N has walk test mode and white light immunity, which can be used to reduce false alarms caused by lights, flashlights or other reflective objects. These outstanding features of the sensor provides the professional security for protecting any home or business to save time, money and deliver a great surveillance experience as well.

## Specification

Frequency	908.4~916 MHz
Battery Type	GP CR123A * 1
RF Transmission Range	Outdoor: 60 Meters
Temperature Sensor	±1° C Accuracy
Rearm Timer	3 Minutes
Operating Temperature	0° C to 50° C (32° - 122°F)
Storage Temperature	-20° C to 65° C (-4° - 149°F)
Battery Life	2 Years (Assume 30 trigger events per day @25°C)
Dimensions (H xW x D)	93.4mm x 50mm x 31.8mm
Detect Range	Distance: Max. 15M (±1M) w/mounting height 1.8M @25°C Angle: Max. 90 (±10) Degree @25°C

## Package Contents

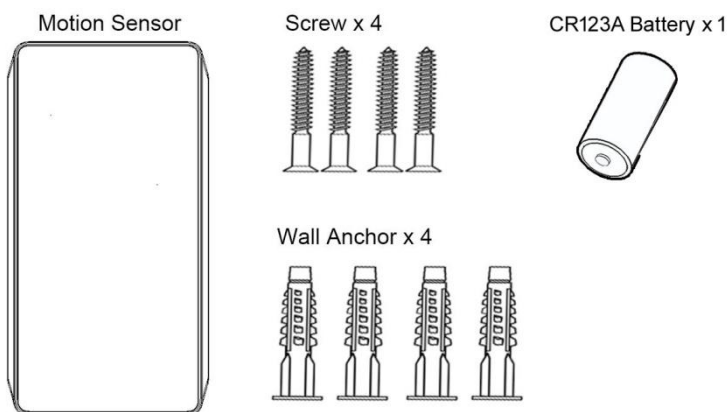

## Installation

1. Detach the mount bracket from the device.
2. Install the provided battery correctly.
3. Attach the mount bracket back to the device.

## Operation

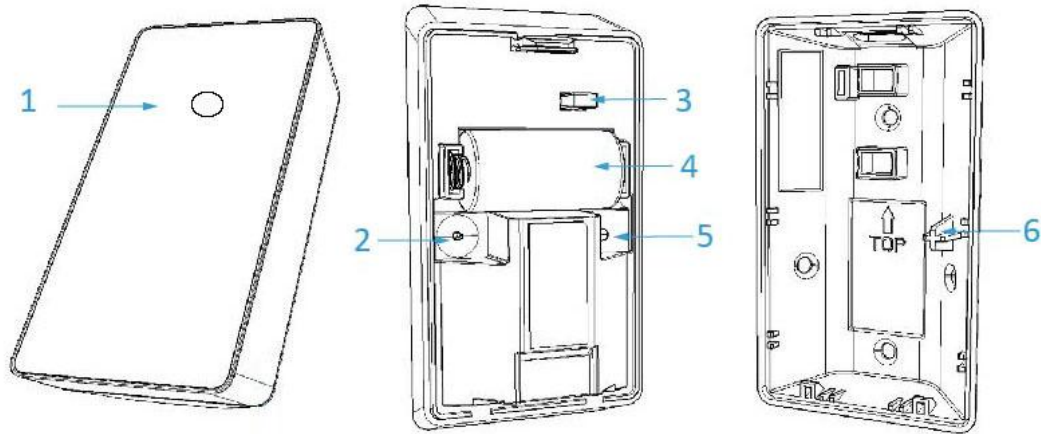

1. PIR LED (Red)	5. Pairing LED (Green)
2. Tamper Switch	6. Battery Cover (Wall Mount Bracket)
3. Jumper (Walk Test)	
4. Battery	

- Remove the protection film on front panel before installation.
- When the battery is installed, the PIR LED will be blinking for 30 seconds and then turn off when the Motion Sensor is ready to be used.
- After the tamper switch is pressed, the Motion Detector will be in normal mode. The PIR LED on the device will illuminate when the Motion Detector is triggered.
- When the Motion Detector is triggered, it will send Basic Set ON (0xFF).
- If no movement detected in three minutes, it will send Basic Set OFF (0x00).

### CAUTION:

**RISK OF EXPLOSION IF BATTERY IS REPLACED BY AN INCORRECTED TYPE. DISPOSE OF USED BATTERIES ACCORDING TO THE INSTRUCTIONS.**

## Add (Inclusion) Sensor

For adding in (Inclusion) a network: Put the Z-Wave controller into "Add (Inclusion)" mode, and follow its instruction to add SW-PIR03N to your controller. This sensor needs to be included before installation.

1. Install the battery and the Pairing LED indicator will be lit for one second to indicate a successful booting.
2. It will blink one time every second while scanning the network.
3. If the network is not found after 30 seconds, the sensor will go into sleep mode. To wake the sensor again, you need to use the tamper switch to trigger the adding (Inclusion) process, and then the sensor will repeat steps from 2 to 3.

## Remove (Exclusion) Sensor

1. Set the Z-Wave controller to "Exclusion" mode.
2. Press the tamper button 3 times within 2 seconds.
3. The PIR LED will light up for 1 second if success.
4. The device will begin to search for a new network.

## Association

Associations (Association Command Class Version 2)

This Sensor supports 2 association groups. This has the effect that when the sensor is triggered, all devices associated with the sensor will receive the relevant reports. Through an association the sensor may control another Z-Wave network device, e.g. a alarm device, wall plug, lamp etc.

Every group can be support to associated 5 devices max.

GROUP 1 is lifeline service that assigned to Sensor (Motion detector) status – Open/Close. It enables the sensor to send reports and readings to a Z-Wave Controller or Z-Wave Gateway whenever the sensor is triggered. This Group Support:

NOTIFICATION\_REPORT\_V4  
DEVICE\_RESET\_LOCALLY\_NOTIFICATION  
COMMAND\_CLASS\_SENSOR\_MULTILEVEL\_V7  
BATTERY\_REPORT

GROUP 2 allows for Sending Basic to associated devices in this group. This Group Support:  
BASIC\_SET

## **Reset to Factory Defaults**

Please reset the device to factory default only when the primary controller is missing or inoperable.

1. Press the tamper switch 4 times within 2 seconds and hold the 4<sup>th</sup> press until the PIR LED lights up.
2. The PIR LED will be off after 3 seconds and all settings will be reset to factory defaults.

## **Walk Test**

1. The PIR will be in “Walk Test” mode for 3 minutes after install the battery. After 3 minutes, the PIR will return to normal operation mode if the “Walk Test” jumper is not installed.
2. If the installer needs longer time to perform walk test, install the “Walk Test” jumper and the PIR will NOT return to normal operation mode.
3. Rearm timer is configured to 2 seconds for walk test and 3 minutes for normal operation mode.
4. To save the battery, remember to remove the jumper after walk test finished.

## Mounting Instruction

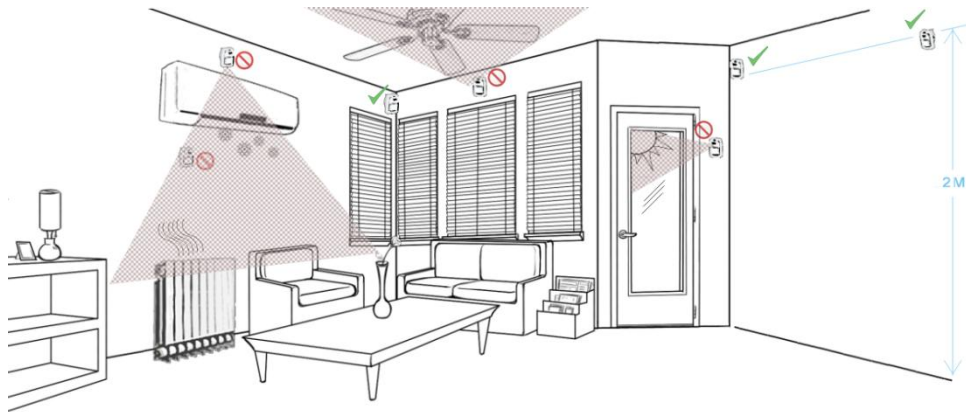

The recommended mounted position for a Motion Detector should be 1.8M from the floor in the corner of a room. At this height, the device can detect a movement up to 15M ( $\pm 1M$ ) (see the following image). Also, in this position, the 90 degrees ( $\pm 10$  degree) fan-shaped detection pattern can normally offer greater protection than mounting on a flat wall.

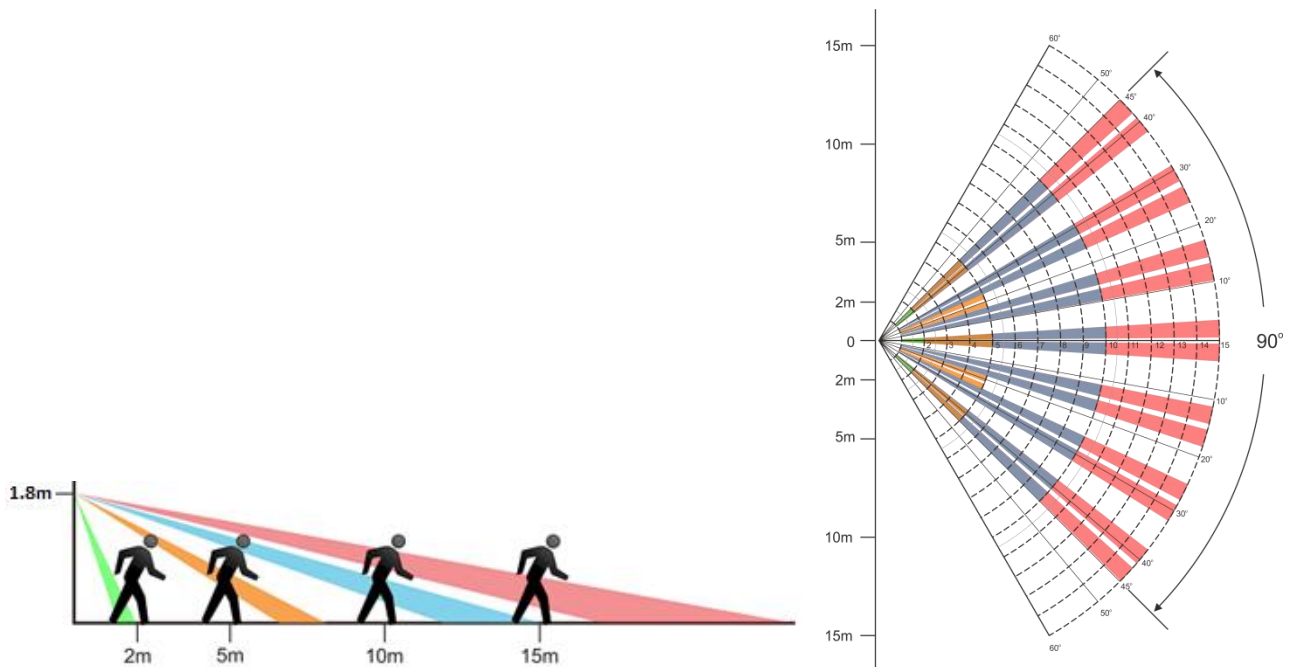

Before selecting a position, the following installation hints should be noted:

1. Do not position the Motion Detector facing a window or direct sunlight. The device is also not suitable for using in draughty area where air conditioner or fan been installed. The excessive wind may cause false alarm.
2. Avoid aiming directly near heat sources, eg: fires, radiators, boiler etc.
3. Mount the detector where possible, so that the logical path of an intruder would cut across the fan pattern rather than directly towards the device.
4. Before mounting the PIR, perform walk test to ensure the detection coverage.

## Wall Mounting

Note: The device is suggested to be set at 90 degrees angle, which is the best mounted position for offering the 15M protection area.

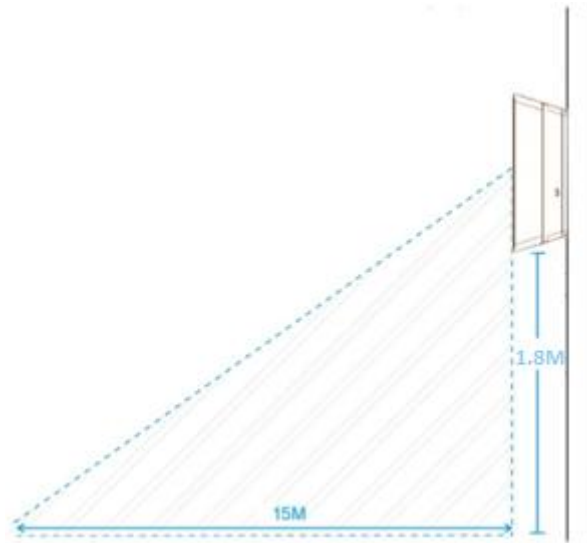

4. Detach the mount bracket from the device.
5. Mount the bracket with the supplied screws/anchors into the wall. It can be either mounted on a flat surface or in a corner.  
**Note:** Make sure the mount bracket is installed in the correct direction (upwards arrow).

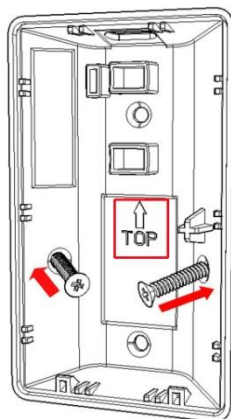

Corner Installation



Flat Wall Installation

6. Attach the device to the mount bracket.

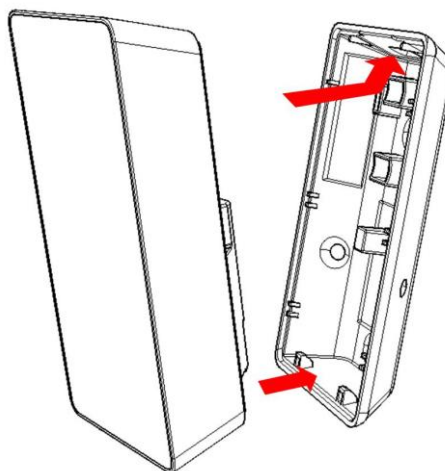

## Z-Wave Command Classes

- COMMAND\_CLASS\_ZWAVEPLUS\_INFO
- COMMAND\_CLASS\_VERSION
- COMMAND\_CLASS\_MANUFACTURER\_SPECIFIC
- COMMAND\_CLASS\_DEVICE\_RESET\_LOCALLY
- COMMAND\_CLASS\_POWERLEVEL
- COMMAND\_CLASS\_BATTERY
- COMMAND\_CLASS\_NOTIFICATION
- COMMAND\_CLASS\_ASSOCIATION
- COMMAND\_CLASS\_ASSOCIATION\_GRP\_INFO
- COMMAND\_CLASS\_BASIC
- COMMAND\_CLASS\_WAKE\_UP
- COMMAND\_CLASS\_FIRMWARE\_UPDATE\_MD
- COMMAND\_CLASS\_SENSOR\_MULTILEVEL
- COMMAND\_CLASS\_CONFIGURATION

## Z-Wave Configuration

Configuration Parameter	Function	Size (Byte)	Configuration Value	Unit	Default Setting	Description
1	Configure motion trigger interval	2	0x0002~0x00B4	1s	180s	After motion detected, ignores consequent motion events during the trigger interval to save battery power. If “Walk Test” jumper is enabled, the interval will be set to 2 seconds and ignores this configuration.

## Notification Type

	Switch Type	Status
Notification Type	PIR ON/OFF	0x07
	Tamper Switch	0x07
Event	PIR ON/OFF	Close:0x00, Open:0x08
	Tamper Switch	Close:0x00, Open:0x03
BASIC Report	PIR ON/OFF	Close:0x00, Open:0xFF

	Alarm V1 (Movement)
Alarm Type	0x07
Alarm Level	0x00 (No movement after 3 mins ) 0xFF (Motion detected)

## FCC Statement

This equipment has been tested and found to comply with the limits for a Class B digital device, pursuant to part 15 of the FCC Rules. These limits are designed to provide reasonable protection against harmful interference in a residential installation. This equipment generates uses and can radiate radio frequency energy and, if not installed and used in accordance with the instructions, may cause harmful interference to radio communications. However, there is no guarantee that interference will not occur in a particular installation. If this equipment does cause harmful interference to radio or television reception, which can be determined by turning the equipment off and on, the user is encouraged to try to correct the interference by one or more of the following measures:

- Reorient or relocate the receiving antenna.
- Increase the separation between the equipment and receiver.
- Connect the equipment into an outlet on a circuit different from that to which the receiver is connected.
- Consult the dealer or an experienced radio/TV technician for help.

This device complies with Part 15 of the FCC Rules. Operation is subject to the following two conditions: (1) this device may not cause harmful interference, and (2) this device must accept any interference received, including interference that may cause undesired operation.

### Caution!

Any changes or modifications not expressly approved by the party responsible for compliance could void the user's authority to operate the equipment.

### FCC Radiation Exposure Statement

This equipment complies with FCC RF radiation exposure limits set forth for an uncontrolled environment. This equipment should be installed and operated with a minimum distance of 20 centimeters between the radiator and your body.

This device complies with Part 15 of the FCC Rules. Operation is subject to the following two conditions:

- (1) This device may not cause harmful interference, and
- (2) This device must accept any interference received, including interference that may cause undesired operation.

This transmitter must not be co-located or operating in conjunction with any other antenna or transmitter.

### FCC RF Radiation Exposure Statement:

- This Transmitter must not be co-located or operating in conjunction with any other antenna or transmitter.
- This equipment complies with FCC RF radiation exposure limits set forth for an uncontrolled environment. This equipment should be installed and operated with a minimum distance of 20 centimeters between the radiator and your body.