

# GE Z-Wave In-wall Touch Sensing Smart Dimmer



2.1"  
(53.3mm)



4.1"  
(104.1mm)

2.8"  
(71.1mm)

1.8"  
(44.5mm)

## Specifications

**Power:** 120VAC, 60Hz **Signal Frequency:** 908.4/916  
**Maximum Load:** 600W Incandescent, 150W Dimmable CFL/LED  
**Range:** Up to 150 feet line of sight between the wireless controller and the closest Z-Wave device  
**Operating Temperature:** 32-104° F (0-40° C)  
**Warranty:** 2-year limited product warranty  
**Requires neutral wire. For indoor use only.**

## Design Features

- Simply tap on, tap off, or convenient zero to 100 percent dimming by simply gliding your finger up and down touch sensing surface or via Z-Wave remote control.
  - May be used in single pole installation or with up to four GE model 12723 Add-on switches in 3, 4, 5 or 6-way wiring configurations
  - UL Listed to work with dimmable LED & CFLs
  - Blue LED indicates switch location in a dark room
  - Can be Included in multiple Groups and Scenes
  - OTA Updatable
  - Utilizes the Z-Wave Firmware Update Meta Data command class for standardized firmware updates Over the Air
  - Supports Advanced Configuration; Dim rates, LED status, Invert switch (if unit is installed upside down)
  - Screw Terminal installation; requires wiring connections for Line (Hot), Load, Neutral and Ground. Traveler wire required for multi pole installation
  - Use a standard-size wall plate
- for single gang installations (wall plate not included); Multi-gang box option available (removable 'side wings')
  - Interchangeable Touch Surface: White & light almond paddle included in package
  - LED can be enabled/disabled manually
  - Inline traveler circuit protection
  - Z-Wave Plus Certified

## Z-Wave Plus Features

- Works with Z-Wave Classic and Z-Wave Plus Products
- 50% more wireless range
- 250% faster processor
- 400% more memory
- 50% more energy efficient
- Supports wireless upgrades to future-proof your home

## White/light almond paddles included



\* Requires Z-Wave hub or controller, functions may vary depending on brand.

Single Location Wiring

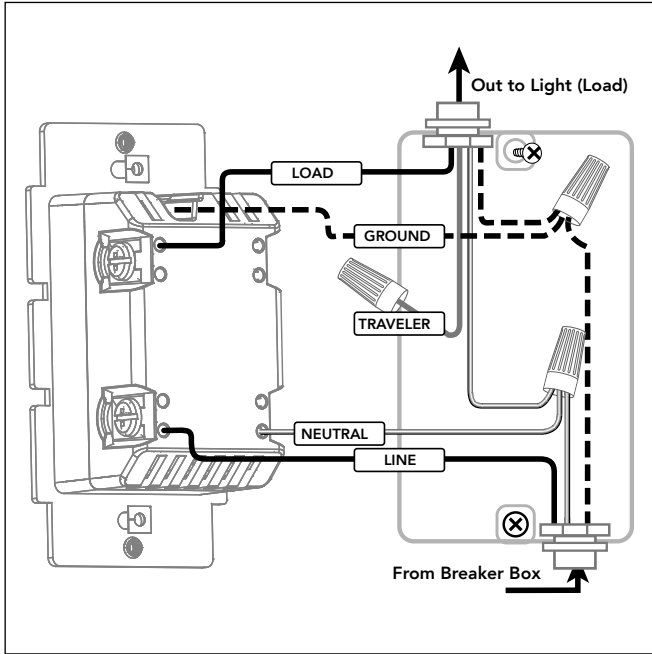

Space-Saving Screw Terminals

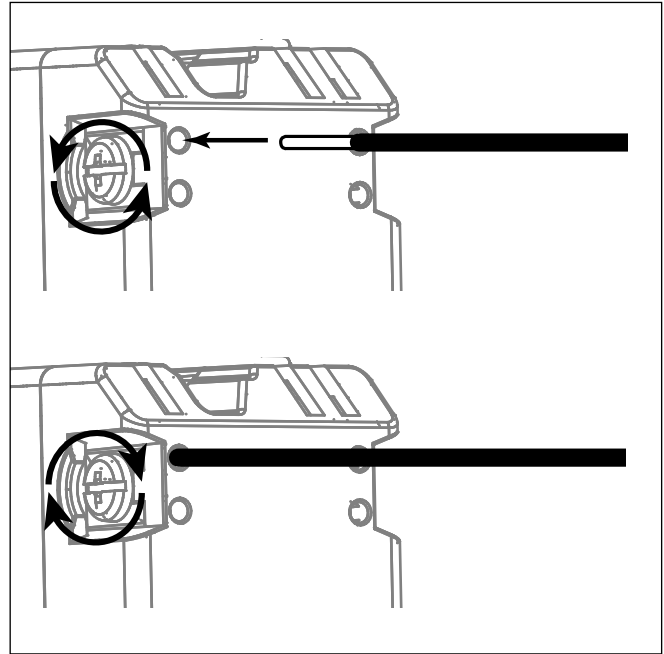

Multi-Location Wiring

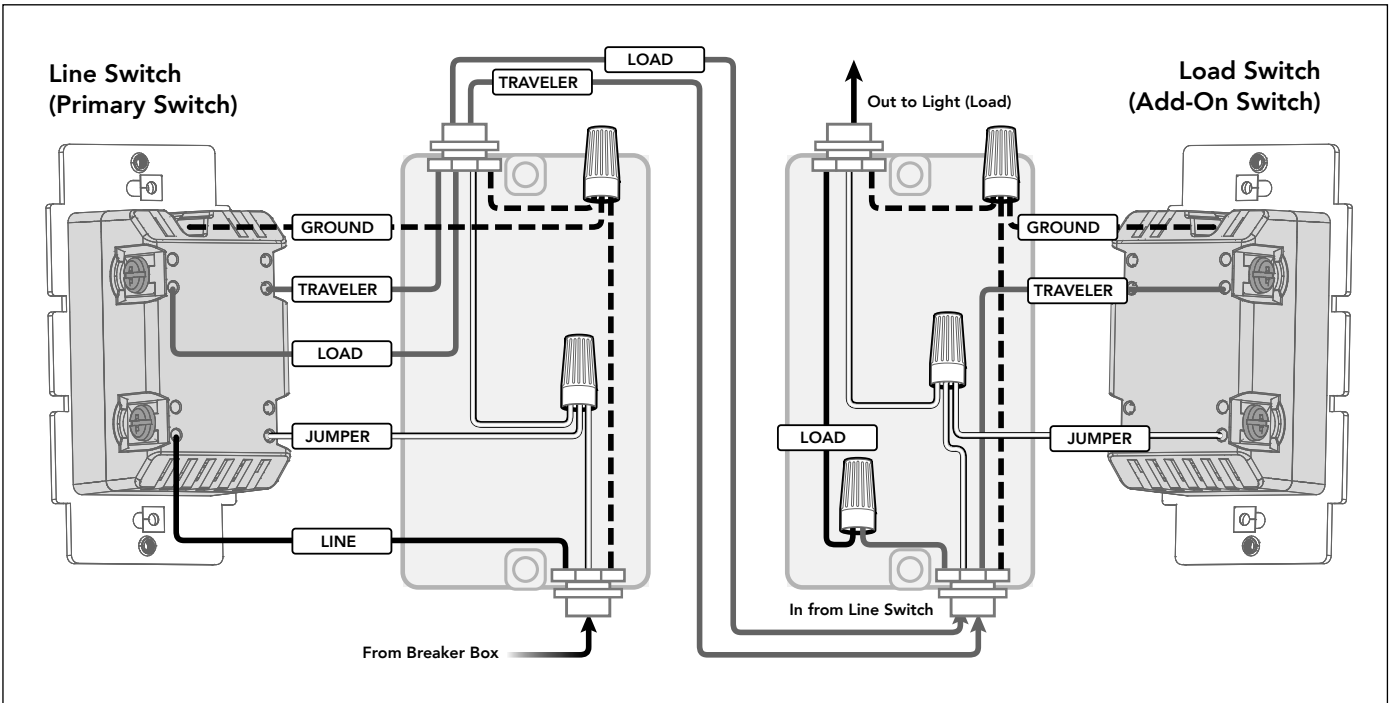

Installation Recommendations:

- Devices require a 1-gang U.S. wall box. 3½ in deep recommended, 2¼ in deep minimum.
- Indoor use only
- Visit <http://www.ezwave.com/hubs/> for hub compatibility
- Wallplates sold separately
- Trilingual Instruction manual – (English, French, Spanish)

**Device Configuration**

**Adding your device to a Z-Wave network**

Once the hub is ready to add your smart dimmer, press and release anywhere on the touch panel to add it in the network.

**To remove and reset the device**

Once the controller is ready to remove your device, press and hold the side button(G) of the smart dimmer to remove it from the network.

**To return to factory defaults**

Press and release side program button(G) three times quickly. The LED will flash ON/OFF five(5) time when completed successfully. All button presses must be completed within five(5) seconds.

**Certifications & Compliances**



Compliances, specifications and availability are subject to change without notice

Distributed by Jasco Products Company LLC  
10 E. Memorial Rd., Oklahoma City, OK

©Jasco 2018

**Related Products - GE Z-Wave Smart Controls**



**12723**  
Add-On  
Switch



**14294**  
In-Wall  
Smart Dimmer



**26931**  
In-Wall Smart  
Motion Switch



**26933**  
In-Wall Smart  
Motion Dimmer



**14288**  
In-Wall  
Smart Outlet